

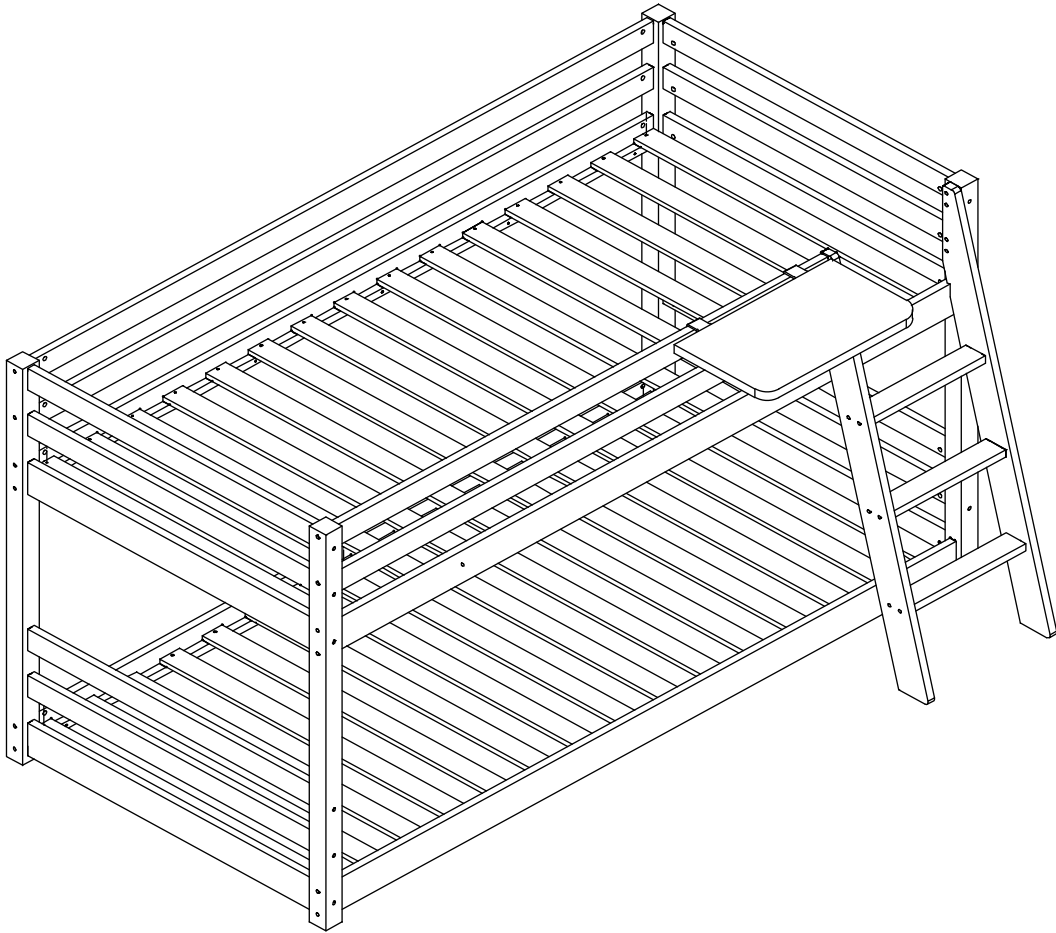

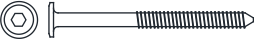









# Assembly Instructions



## HARDWARE



<p><b>A</b></p>  <p>M6X90 46pcs</p>	<p><b>B</b></p>  <p>M6X60 4pcs</p>	<p><b>C</b></p>  <p>M6 48pcs</p>	<p><b>D</b></p>  <p>φ8X30 50pcs</p>	<p><b>E</b></p>  <p>M3X15 8pcs</p>
<p><b>F</b></p>  <p>M6X18 2pcs</p>	<p><b>G</b></p>  <p>M4X30 60pcs</p>	<p><b>H</b></p>  <p>M6X50 13pcs</p>	<p><b>J</b></p>  <p>2pcs</p>	<p><b>K</b></p>  <p>2pcs</p>
<p><b>L</b></p>  <p>M4X35 2pcs</p>	<p><b>N</b></p>  <p>4pcs</p>			

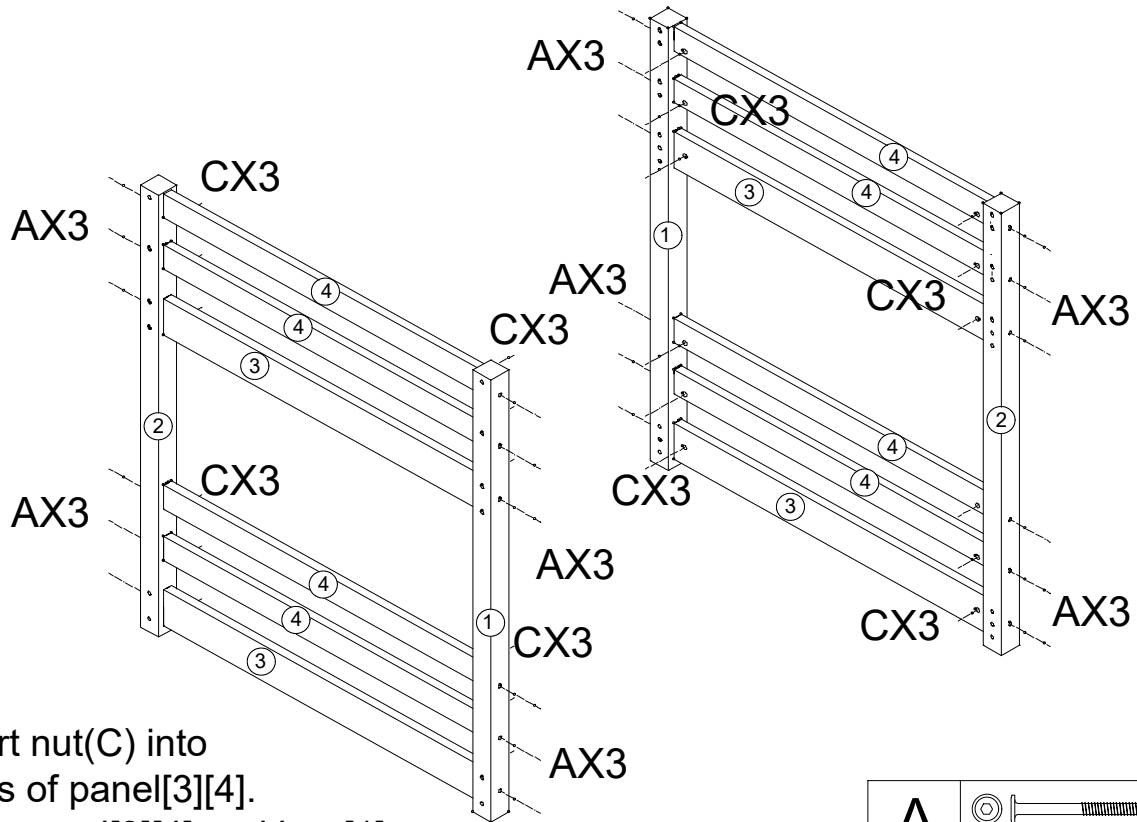

# 2



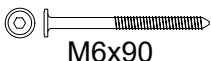

Insert nut(C) into sides of panel[3][4].  
Lock panel[3][4] and bar [1][2] with bolt(A).

A	 M6x90	24
C	 M6	24

# 3

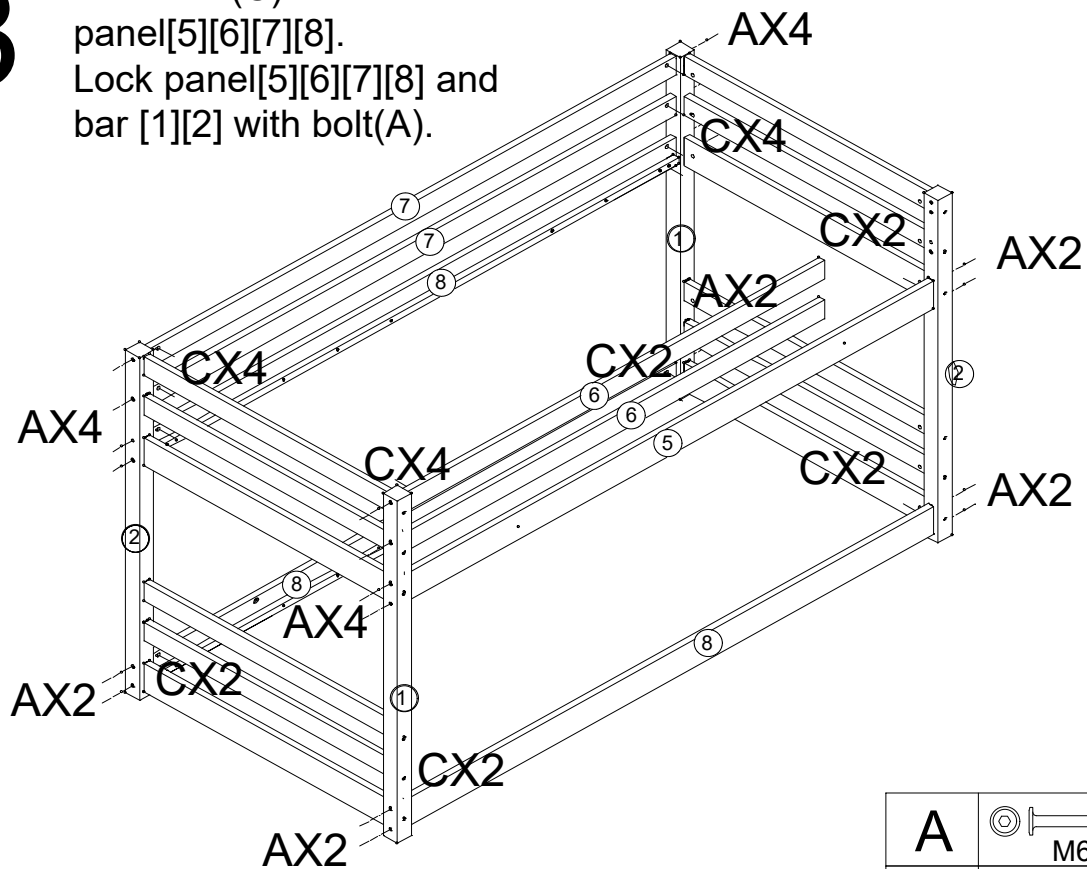
Insert nut(C) into sides of panel[5][6][7][8].  
Lock panel[5][6][7][8] and bar [1][2] with bolt(A).

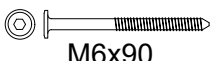

A	 M6x90	22
C	 M6	22

# 4

Lock 2x panel[9] and 3x panel[11] with 12x screw(H) to form the ladder.

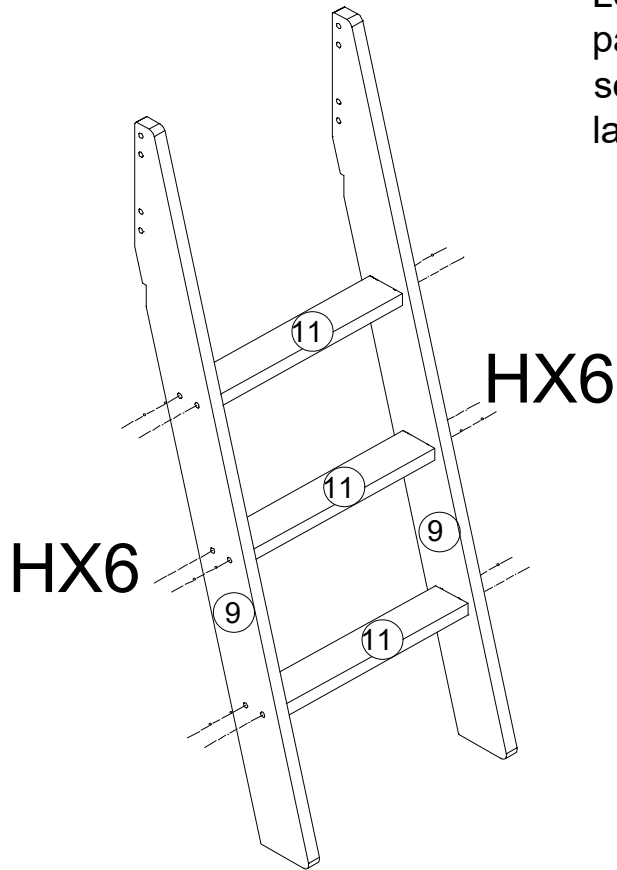

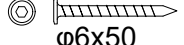

H	 φ6x50	12
---	--	----

# 5

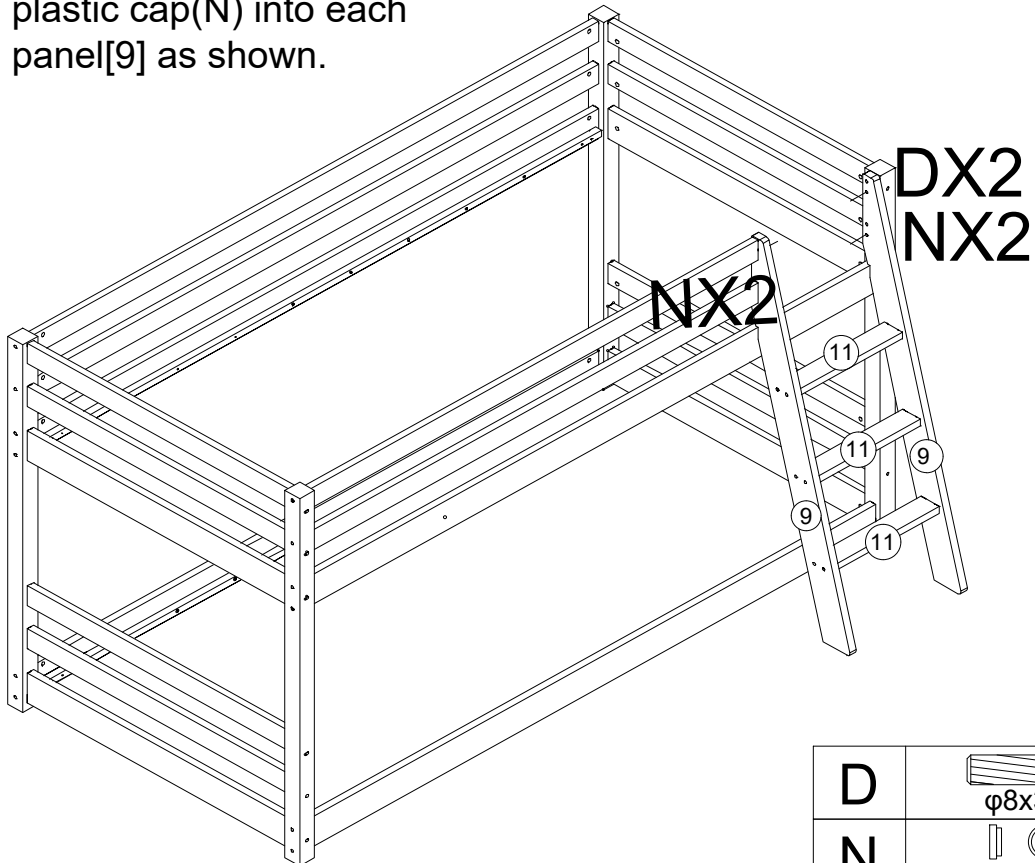
Insert 2x dowel (D) and 4x plastic cap(N) into each panel[9] as shown.





D	 φ8x30	2
N	 φ6x50	4

# 6

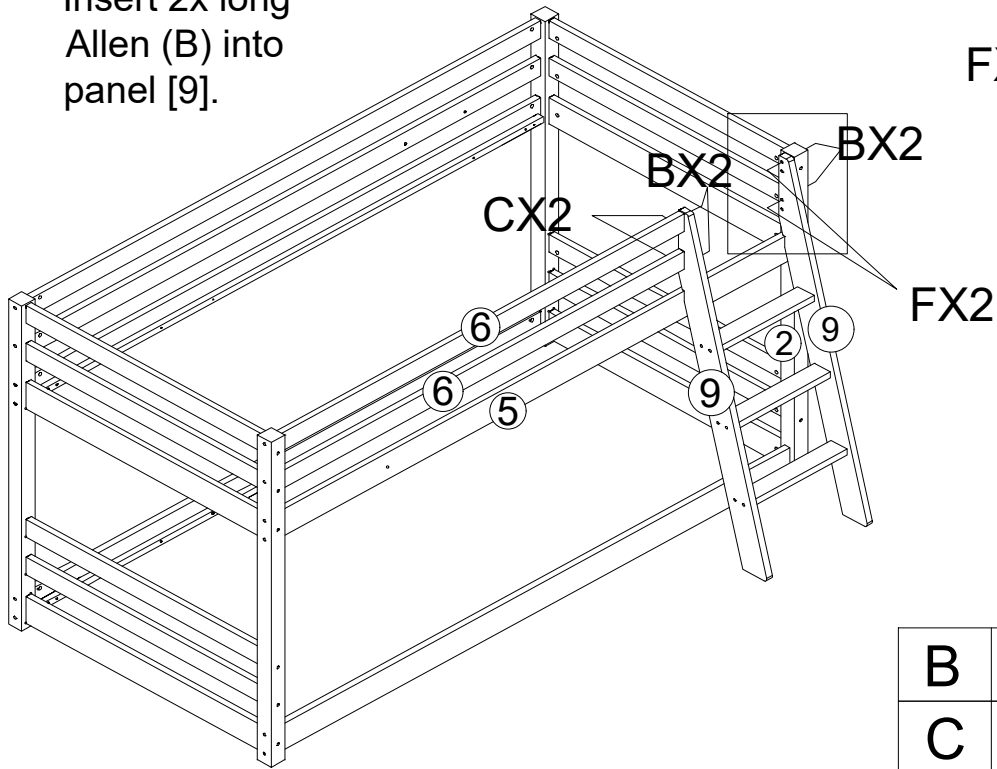
Insert 2x nut(C) into  
2x panel [6].  
Insert 2x long  
Allen (B) into  
panel [9].



Lock another panel[9] and bar [2] with 2x bolt(B).

B	 M6x60	4
C	 M6	2
F	 M6x18	2

# 7

Insert 1x screw (H)  
into panel [5] to lock  
panel [9] as shown.

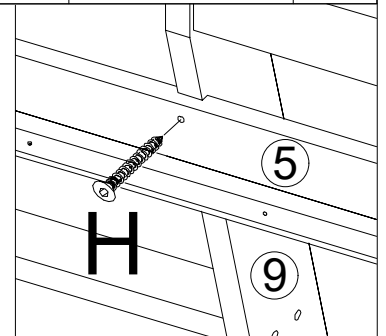
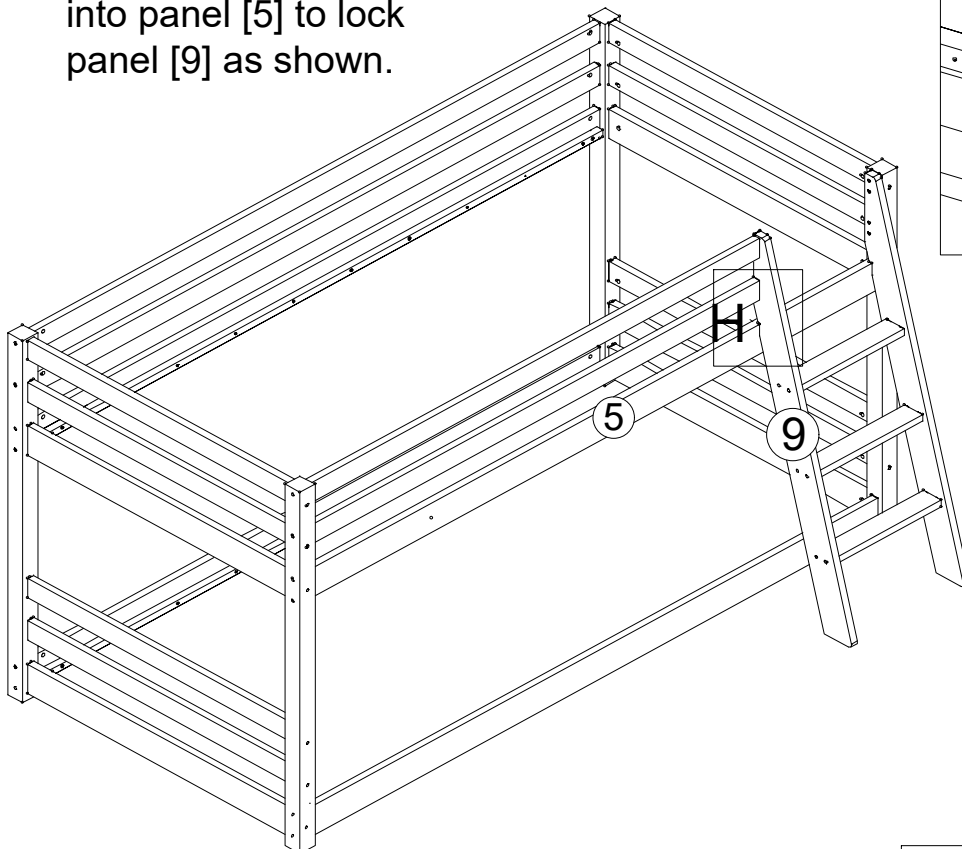

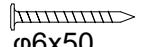

H	 $\phi$ 6x50	1
---	---	---

# 8

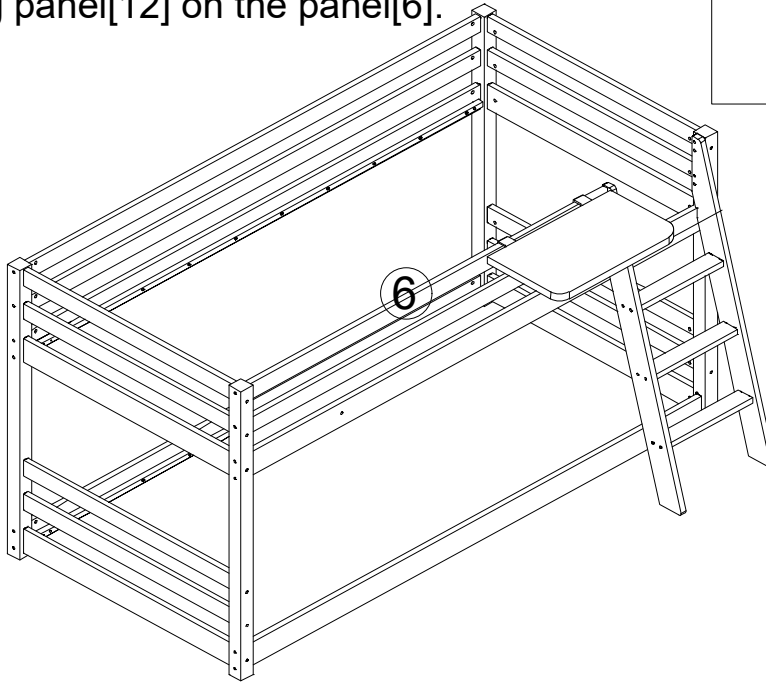
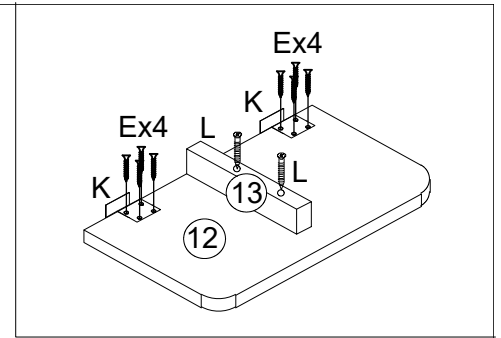
Insert 2x screw(L) into panel [13] and lock with panel [12].  
Insert 8x screw(E) into 2x(K) then lock with panel[12].  
Hang panel[12] on the panel[6].

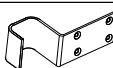

E	 $\phi 3 \times 15$	8
K		2
L	 $\phi 4 \times 35$	2

# 9

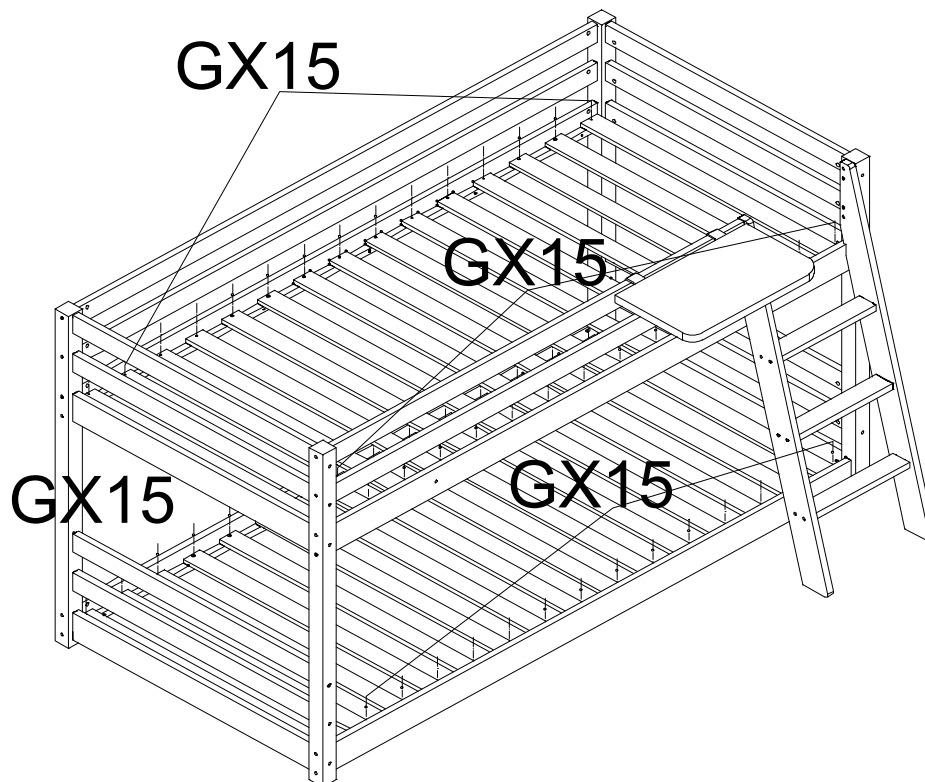

Insert 60x screw(G) into the holes of slats as shown.

G	 $\phi 4 \times 30$	60
---	--	----

# **RETURN / DAMAGE CLAIM INSTRUCTIONS**

## 1. **DO NOT** discard of the box / original packaging.

In case a return is required, the item must be returned in original box. Without this your return will not be accepted.

## 2. Take a photo of the box markings.

A photo of the markings (text) on the box is required in case a part is needed for replacement. This helps our staff identify your product number to ensure you receive the correct parts.

## 3. Take a photo / Video of Damage (if applicable).

A photo /Video of the damage is always required to file a claim and get your replacement or refund processed quickly. Please make sure you have the box even if it is damaged.

## 4. Send us an email with the images requested.

Email us directly with the attached images, order number (SOXXXX) and a description of your claim.

Auckland / Waikato / BOP Branch: [sales@tsbliving.co.nz](mailto:sales@tsbliving.co.nz)  
Christchurch Branch: [customersupport@tsbliving.co.nz](mailto:customersupport@tsbliving.co.nz)  
Wellington Branch: [wellington@tsbliving.co.nz](mailto:wellington@tsbliving.co.nz)