

# OWNER'S MANUAL

Safety Notice	1
Exploded View	2
Part List	3-4
Assembly Instructions	4-8

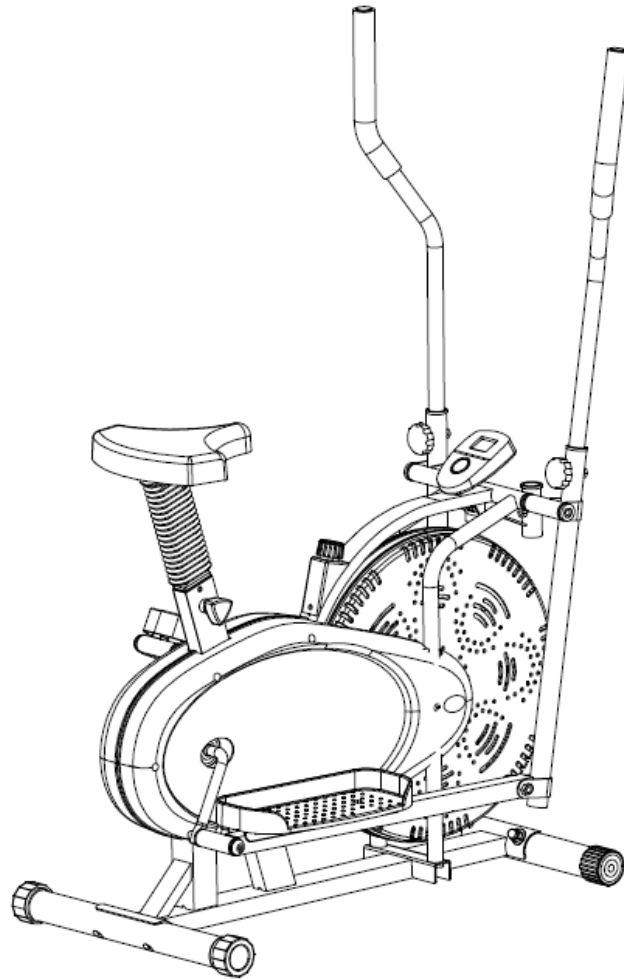

## **IMPORTANT!**

Please read all instructions carefully before using this product. Retain this manual for future reference.

Dear Customer, Please read this instruction very carefully before using the item.

## **IMPORTANT SAFETY NOTICE:**

Note the following precaution before assembling or operating the machine

- 1、 Assemble the machine exactly as the descriptions in the instruction manual.
- 2、 Check all the screws, nuts and other connections before using the machine for the first time and ensure that the trainer is in the safe condition.
- 3、 Set up the machine in a dry level place and leave it away from moisture and water.
- 4、 Place a suitable base (e.g. rubber mat, wooden board etc.) beneath the machine in the area of assembly to avoid dirt and etc..
- 5、 Before beginning training, remove all objects within a radius of 2 meters from the machine.
- 6、 Do not use aggressive cleaning articles to clean the machine, only use the supplied tools or suitable tools of your own to assemble the machine or repair any parts of machine. Remove drops of sweat from the machine immediately after finishing training.
- 7、 Your health can be affected by incorrect or excessive training. Consult a doctor before beginning a training program. He can define the maximum setting (Pulse. Watts. Duration of training etc) to which you may train yourself and can get precise information during training. This machine is not suitable for therapeutic purpose.
- 8、 Only do training on the machine when it is in correct working way. Use only original spare parts for any necessary repairs.
- 9、 This machine can be used for only one person's training at a time.
- 10、 Wear training clothes and shoes, which are suitable for fitness training with the machine. Your training shoes should be appropriate for the trainer.
- 11、 If you have a feeling of dizziness, sickness or other abnormal symptoms, please stop training and consult a doctor.
- 12、 People such as children and handicapped persons should only use the machine in the presence of another person who can give aid and advice.
- 13、 The power of the machine increases with increasing the speed, and the reverse. The machine is equipped with adjustable knob, which can adjust the resistance.
- 14、 The maximum user's weight is 250LBS. Persons whose body weight exceeds this limit should not use this machine.

# Exploded-View

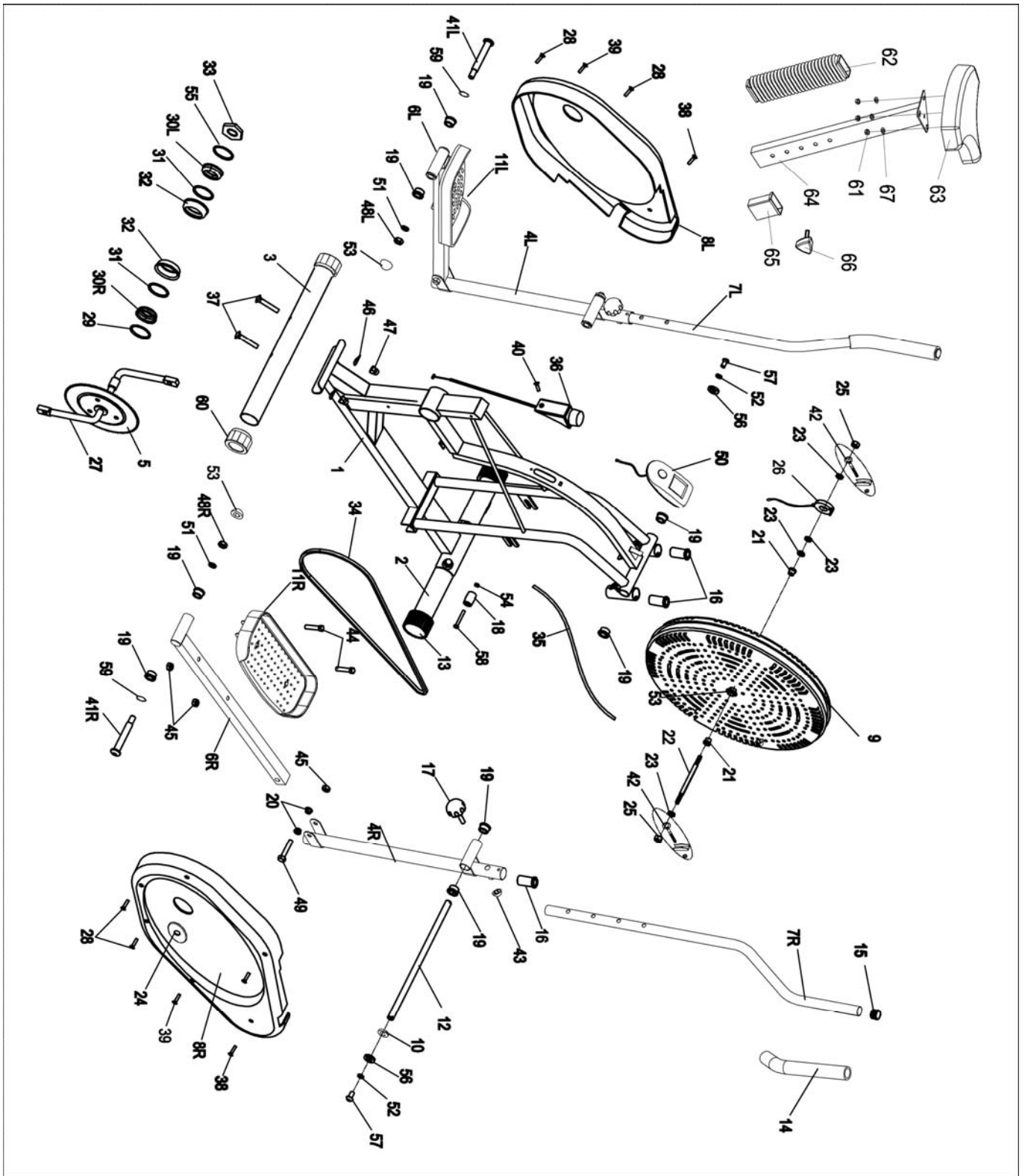



#46 M10x57 4PCS



#46B d10 4PCS



#47 M10 4PCS



#57 M10x18 2PCS



#52 d10.5 2PCS



#56 d16 2PCS



#66 d16 1PC



#12BR 1/2 X89 1PC



#12BL 1/2 X89 1PC



#51  $\phi$ 13xB2 2PCS



#48R 1/2 XB8 1PC



#48L 1/2 XB8 1PC



#48L 1/2 XB8 1PC



#49 S13 2PCS



#41 S18 2PCS

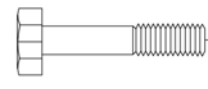

#44 M10x45 4PCS



#45 M10 4PCS



#17 M8x36.5 2PCS



S8 1PC

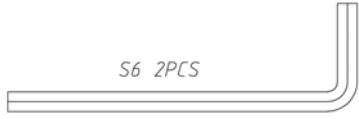

S6 2PCS

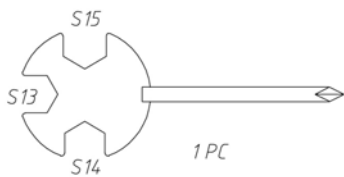

1PC

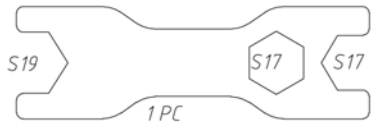

1PC

# PART LIST

Item No.	Description	QTY	Item No.	Description	QTY
1	Main Frame	1	34	Chain 25Hx220L	1
2	Front Bottom Tube	1	35	Tension Belt	1
3	Rear Bottom Tube	1	36	Tension Control	1
4L	Left Pedal Support	1	37	Tension Spring	4
4R	Right Pedal Support		38	Chain Cover Screw	2
5	Chain Wheel	1	39	Chain Cover Screw	3
6L	Left Pedal Tubing	1	40	Tension Fix Screw	1
6R	Right Pedal Tubing		41L	Left Pedal Hinge Bolt Φ16×89×1/2	1
7L	Left Handlebar	1	41R	Right Pedal Hinge Bolt Φ16×89×1/2	1
7R	Right Handlebar		42	Nut	2
8L	Left Chain Cover	1	43	Cap S13	2
8R	Right Chain Cover		44	Bolt M10X45	4
9	Fan Wheel	1	45	Cap	6
10	Adjustable Washer	1	46	Washer	4
11L	Left Pedal	1	47	Acorn Nut M8	4
11R	Right Pedal	1	48L	Left Nut 1/2"×B8	1
12	Handle Bar Shaft	1	48R	Right Nut 1/2"×B8	1
13	End Caps	2	49	Bolt M10X55	2
14	Foam Grips	2	50	Meter	1
15	End Caps	6	51	Spring Washer Φ13×B2	2
16	Plastic Bushing	4	52	Spring Washer Φ10.5	2
17	Knob	2	53	Cap S18	2
18	Plastic Roller	2	54	Nut	2
19	Big Steel Bushing	10	55	Washer	1
20	Small Steel Bushing	4	56	D Shape Wahsher	2
21	Brass Bushing	2	57	Nut M10X18	2
22	Fan Wheel Axle	1	58	Bolt	2
23	Nut	4	59	Waher	2
24	End Caps	2	60	End Caps	2
25	Nut	2	61	Nylon nut M8	3
26	Sensor	1	62	Bellow	1
27	Crank	1	63	Seat	1
28	Chain Cover Screw	4	64	Seat tube	1
29	Nut	1	65	Seat post bushing	1
30L	Left Collar Housing	1	66	Tri-knob	1
30R	Right Collar Housing	1	67	Washer D8	3
31	Collar Ball	2			
32	Collar Housing	2			
33	Collar Housing	1			

## ASSEMBLY INSTRUCTIONS:

### 1.PREPARATION:

- A. Before assembling make sure that you will have enough space around the item.
- B. Use the present tooling for assembling.
- C. Before assembling PLEASE CHECK WHETHER ALL NEEDED PARTS ARE AVAILABLE (AT THE ABOVE OF THIS INSTRUCTION SHEET YOU WILL FIND AN EXPLOSION DRAWING WITH ALL SINGLE PARTS (marked with numbers) which this item consists of.

### 2.ASSEMBLY INSTRUCTIONS:

**Step One: Lock the Front/Rear Bottom Tubes(2/3) to the Main Frame(1) with Tension Spring(37), Wahser(46) and Acorn Nut M8(47).**

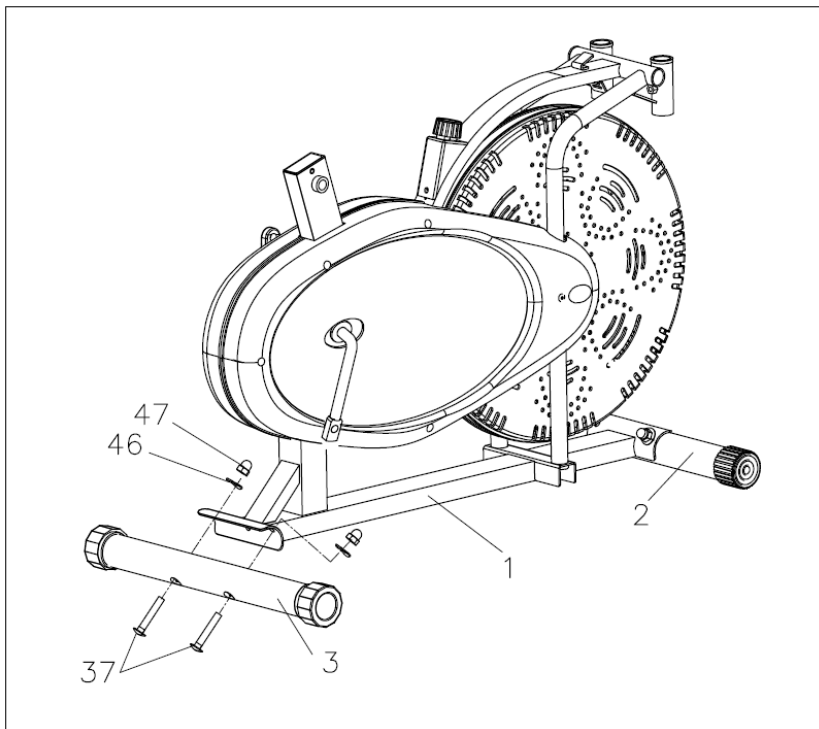

**Step Two: Lock the L/R Pedal Support(4L/R) to the Main Frame(1) with Handle Bar Shaft(12), Nut(57), Spring Washer(52), D Shape Washer(56) and Adjustable Washer(10), do not need to lock tight this time; Then lock the Right Pedal Tubing(6R) tight to the Right Crank(27R) with Right Pedal Hinge Bolt(41R), Washer(59), Spring Washer(51) and Right Nut(48R); Use the same way to lock the Left Pedal Tubing(6L) tight to the Left Crank(27L). Please notice that the Bolt/Nut has Right and Left sides, screw in the Right one with clockwise; screw in the Left one with anticlockwise. When you screw in the bolts, you can rotate the Crank, choose a best degree so as to screw in easily and smoothly.**

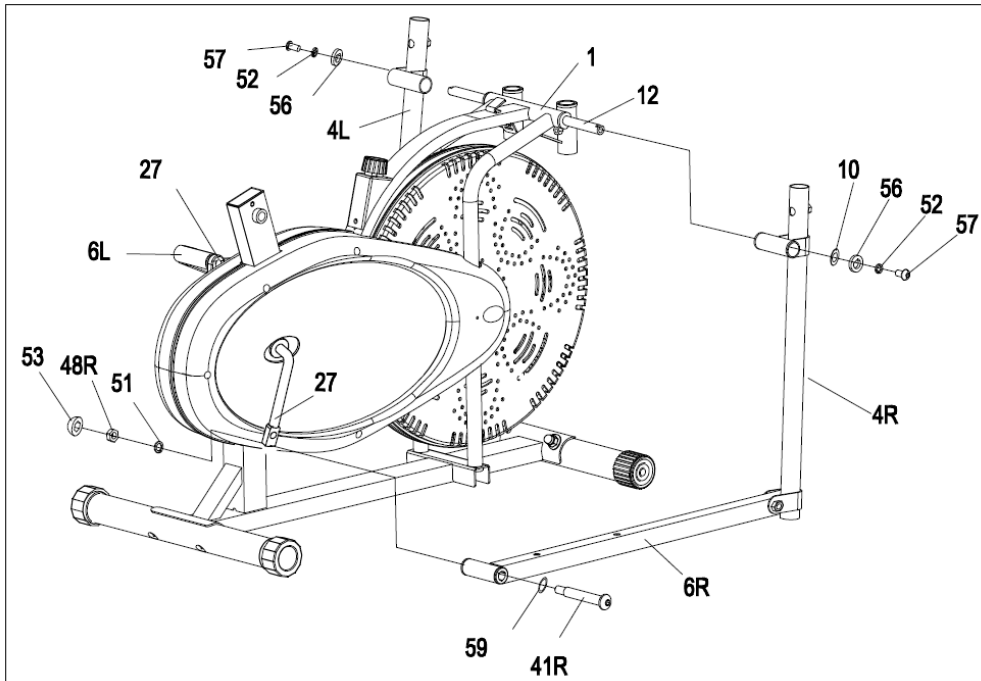

**Step Three: Lock tight the L/R Pedals(11L/R) to the L/R Pedal Tubing(6L/R) with Bolt(44), Cap(45).**

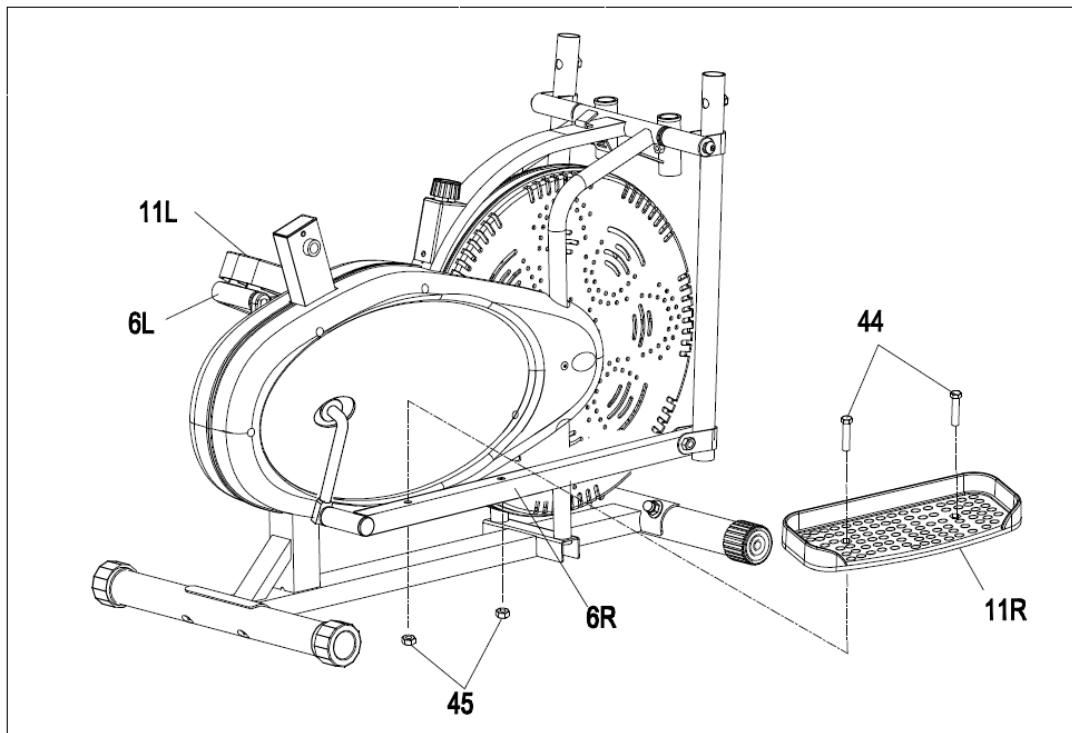

**Step Four: Lock the L/R Handlebars(7L/R) to the L/R Pedal Supports(4L/R) with Knob(17), then cover the Cap(43). You can adjust the height of the handlebars with different holes on the handlebars.**

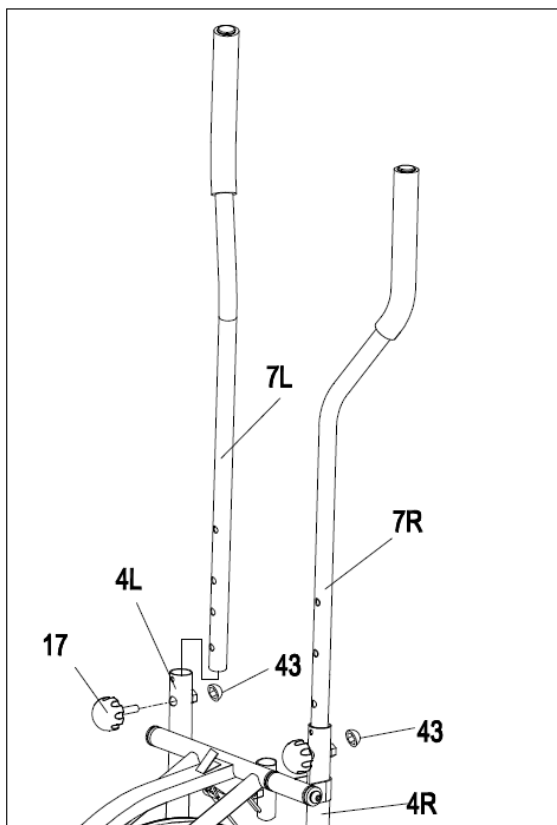

**Step Five:  
Connect the Sensor Wire (26) with the Meter Wire(50),  
Then insert the meter(50) into  
The meter plate on the Main  
Frame(1).**

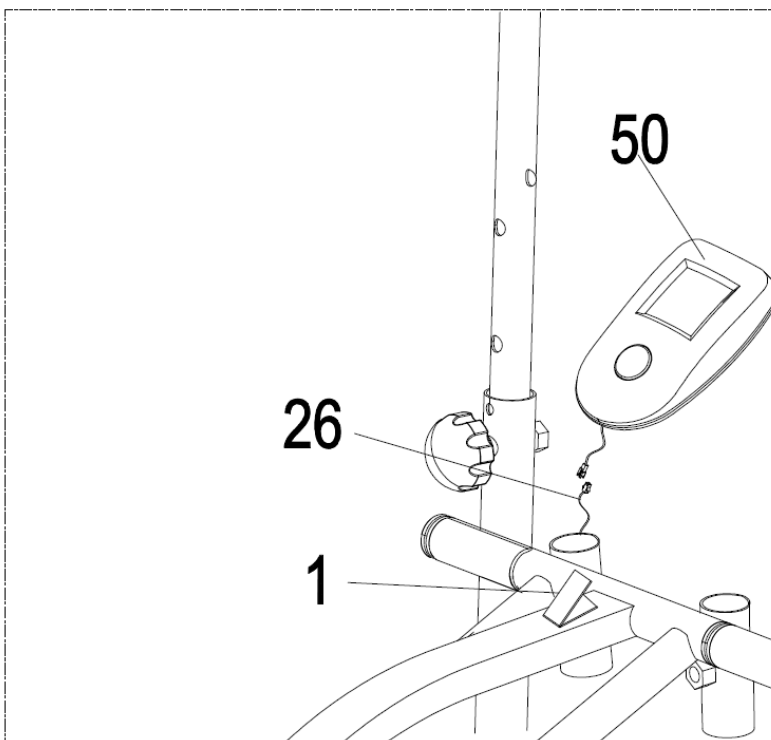

**Step Six:**

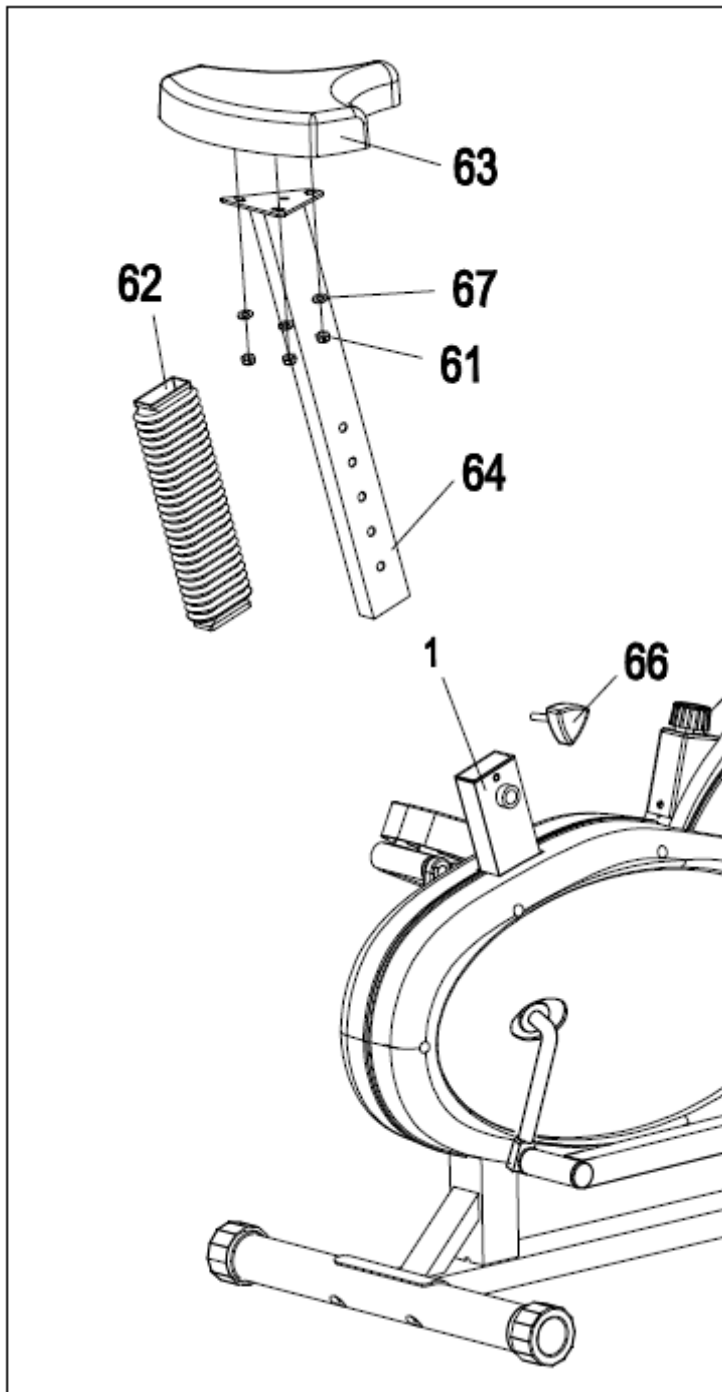

The assembly of your strider is now complete. When you try it for the first time, you should adjust the tension to the correct level before you begin a full workout.

For minute tension adjustment, simply use the Tension Adjustment Knob (pt.34). Turning the adjustment knob allows you to change the tension level and vary the intensity of your workout as you exercise.

For greater tension adjustment, you may loosen or tighten the friction belt by re-strapping it. To do so, first turn the tension adjustment knob to the loosest setting. Then re-strap the belt at the buckle on the top of the fan wheel just beneath the center beam.

The more length you allow on the friction belt the less friction it will cause (less tension). Re-adjust the tension knob after you finished re-strapping.

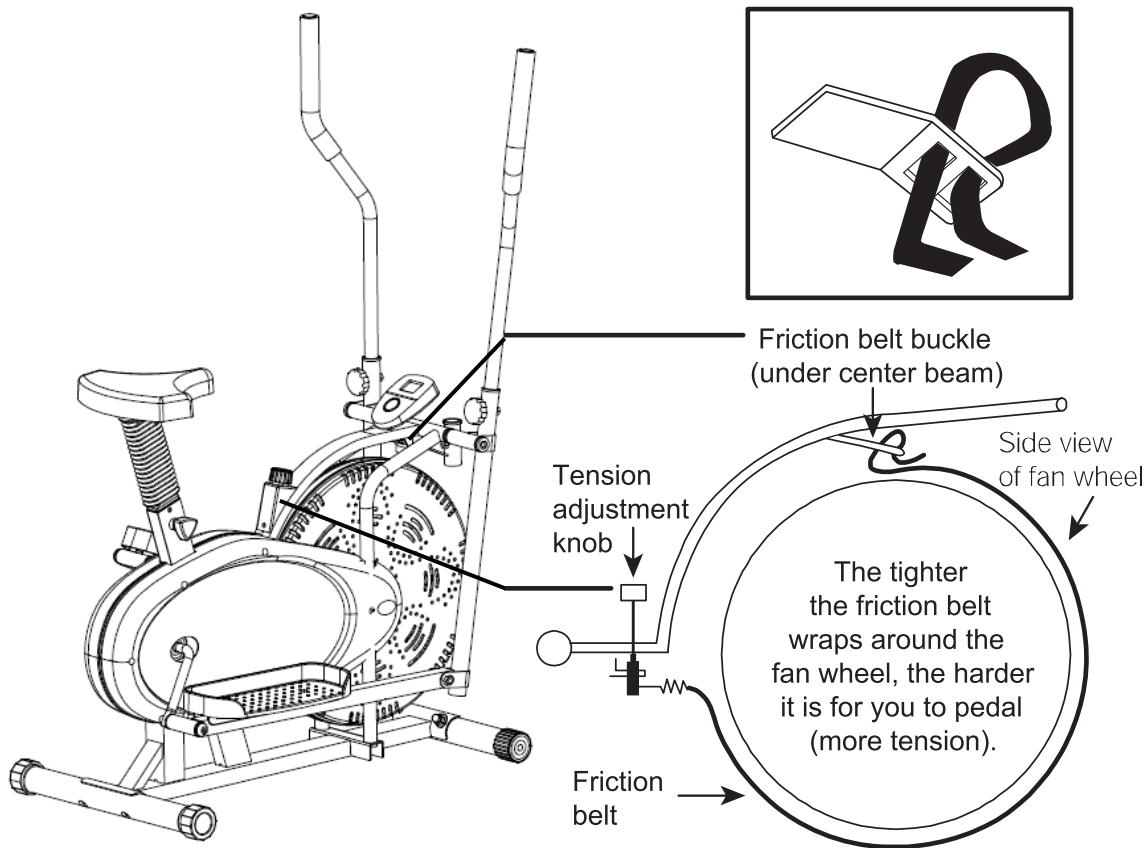

### **REVERSIBLE MOVEMENT**

Remember, your strider has **REVERSIBLE** movement!

Forward pedaling exercises your quadriceps (front thigh muscles), while backward pedaling targets your hamstrings (back thigh muscles).

Take advantage of these facts to make your workout less fatiguing and more fun.

**CAUTION: MAKE SURE YOU HAVE TIGHTENED ALL THE BOLTS AND NUTS WELL BEFORE BEGINNING YOUR WORKOUT.**

**NOTE: THE END CAP ON THE FRONT STABILIZER TUBE IS MOVABLE, WHICH IT IS EASY FOR YOU TO MOVE YOUR TRAINING BIKE, AND THE END CAP ON THE REAR STABILIZER CAN ADJUST THE PARALLELISM.**

## EXERCISE COMPUTER

### BUTTON FUNCTIONS:

**MODE:** PRESS TO SELECT FUNCTION, AND  
HOLD ON FOR 4 SECONDS FOR A TOTAL  
RESET.

### FUNCTIONS

**SCAN** AUTOMATICALLY SCANS THROUGH EACH  
FUNCTION AT INTERVALS OF 6 SECONDS.

**TIME** DISPLAYS TOTAL WORKING TIME UP TO 99:59  
MINUTES.

**SPEED** DISPLAYS THE CURRENT SPEED UP TO 99.9KM/H OR  
ML/H. THE VALUE WILL STAY ON THE MONITOR  
CONTINUOUSLY.

**DISTANCE** DISPLAYS TOTAL WORKING DISTANCE OF UP TO  
99.99KM OR ML FROM ZERO.

**CALORIES** DISPLAYS CALORIE CONSUMPTION DURING EXERCISE.  
MAXIMUM VALUE IS 9999 CALORIES

(THIS DATA IS A ROUGH GUIDE FOR COMPARISON OF DIFFERENT  
EXERCISE SESSIONS AND SHOULD NOT BE USED AS A BASIS FOR  
MEDICAL TREATMENT)

### NOTE:

1. WHEN YOU STOP EXERCISING, A "STOP" SIGN WILL APPEAR ON THE UPPER-LEFT CORNER OF THE MONITOR.
2. IF THERE IS NO SIGNAL FOR A PERIOD OF 4 MINUTES, THE DISPLAY WILL SHUT DOWN AUTOMATICALLY WITH ALL FUNCTION VALUES STORED.
3. TURN ON THE MONITOR BY PRESSING THE BUTTON OR BY PEDALING.
4. IF MONITOR DISPLAY IS FAULTY, PLEASE TRY REINSTALLING THE BATTERIES.
5. BATTERY SPEC: 1.5V UM-3 OR AA (2PCS).

### TROUBLESHOOTING.

1. **Changing the batteries.** To change the computer batteries, please slide the computer from the computer holder, remove the battery cover on the back of the computer console, and remove the batteries. Replace with 2 x AA batteries. Finally, put the cover back on the console, and slide the computer back onto the computer holder.

2. **Computer not working correctly.** If your computer is not working correctly, please check whether the computer sensor wire is plugged into the computer. If you have checked the above and the computer is still not working, then please make sure the batteries are still working and that they are installed correctly in the computer.

**No resistance.** If there is no tension resistance, please turn the tension adjustment knob to its lowest level, and then go to the friction belt buckle which is located on top of the fan wheel beneath the center beam. Loosen the friction belt, pull it through the buckle until you can feel some resistance on the belt, and then lock it back around the buckle. Now mount your Aero Elliptical Strider and turn the pedals. If you find it is now too tight, go back to the friction belt buckle and loosen the belt slightly.