

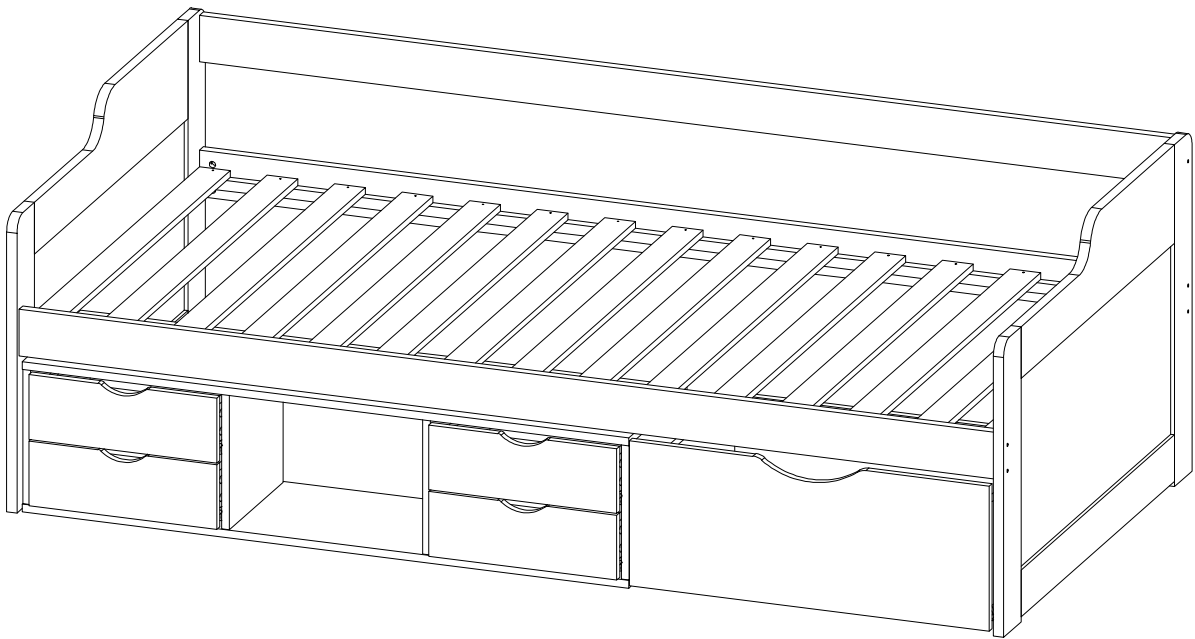









Assembly Instructions

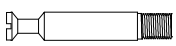

HARDWARE

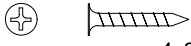
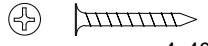
									
	M6x60	M6	\varnothing 8x30	\varnothing 6x34	\varnothing 15x11				
A	10	B	10	C	16	D	28	E	28
	\varnothing 35		\varnothing 3x14		\varnothing 4x30		\varnothing 4x40		M4
F	04	G	08	H	30	I	28	J	01

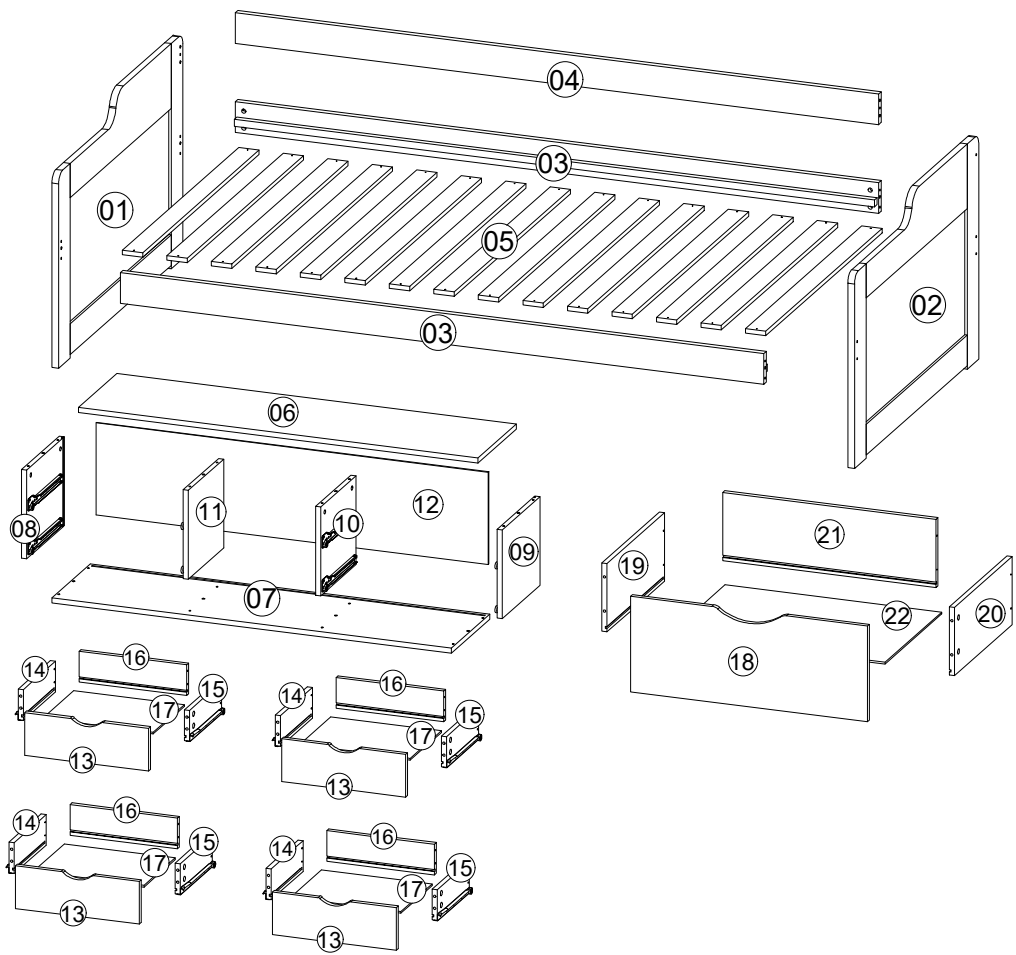

01

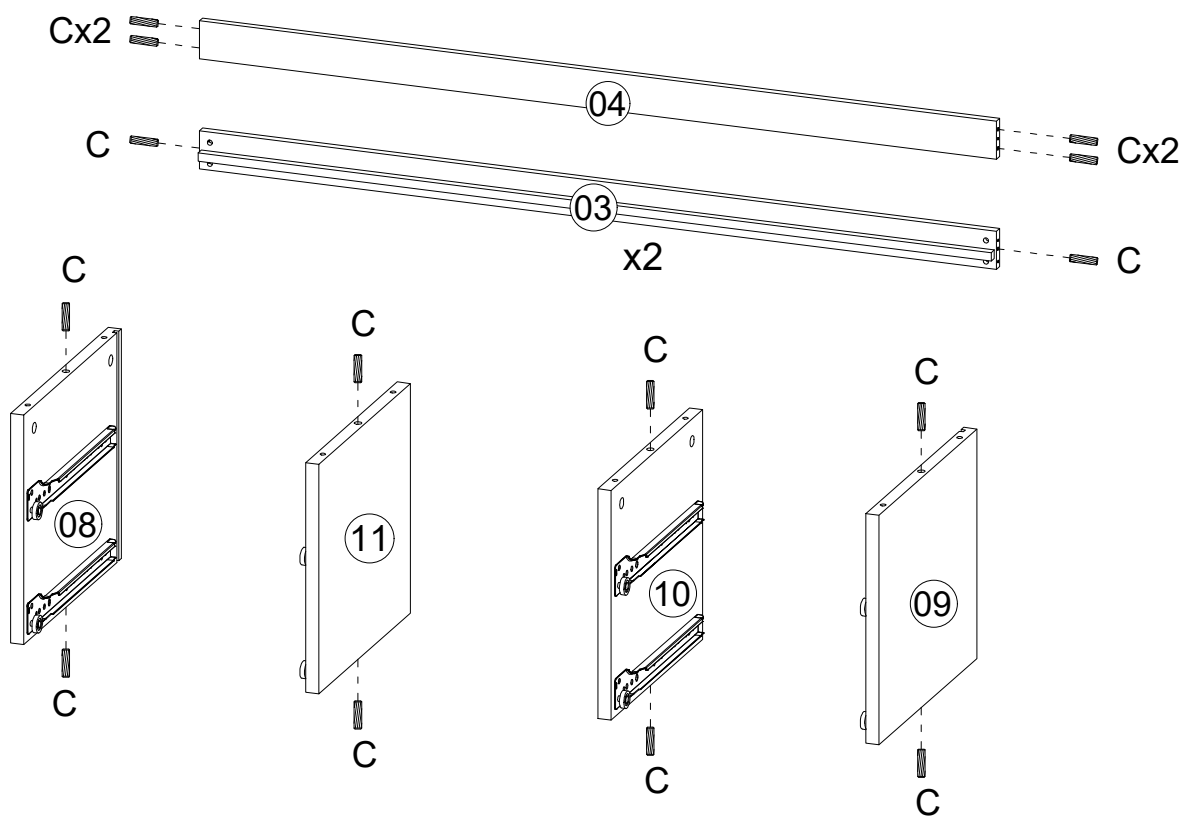

Insert dowel(C) into panel [3][4][8][9][10][11].

C		16
	φ8x30	

02

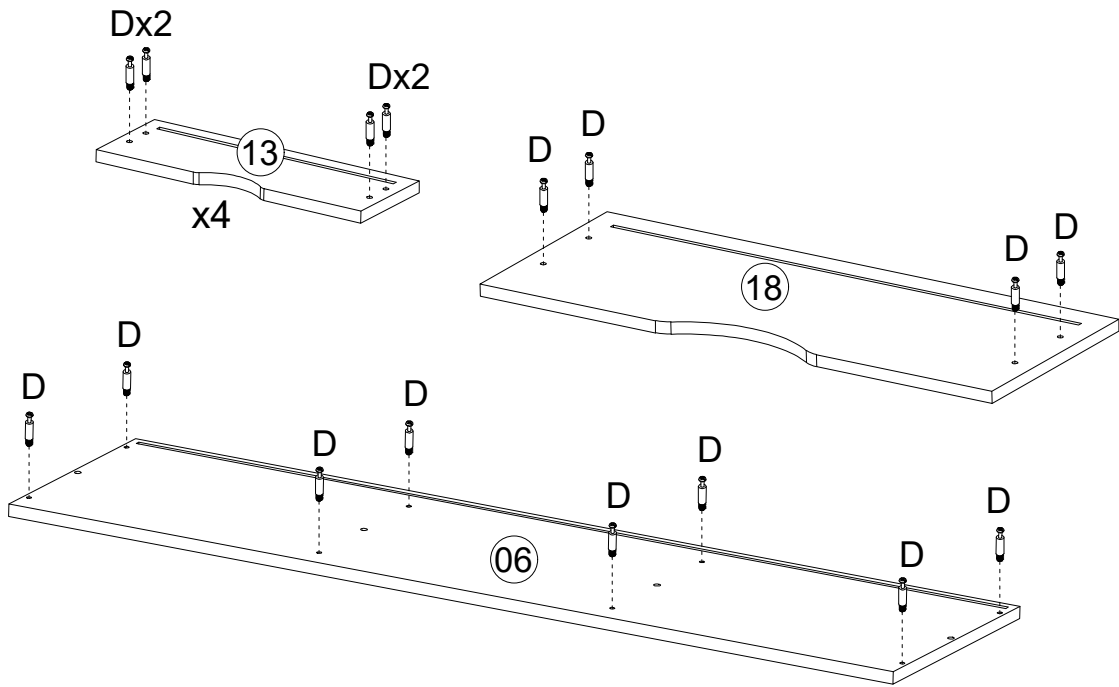



Insert bolt(D) into panel [6][13][18].

D		28
	φ6x34	

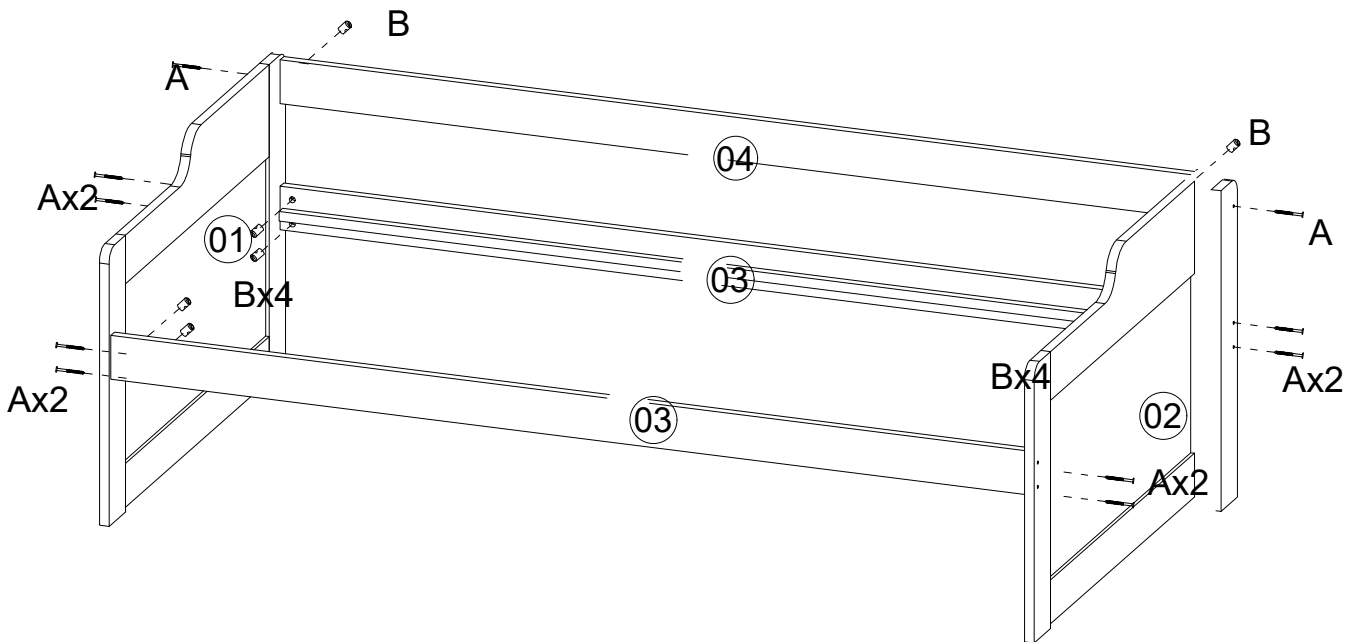
03



Attach panel [1][2] to panel [3][4] and secure with screw(A) and nut (B).

A		10
	M6x60	
B		10
	M6	

04

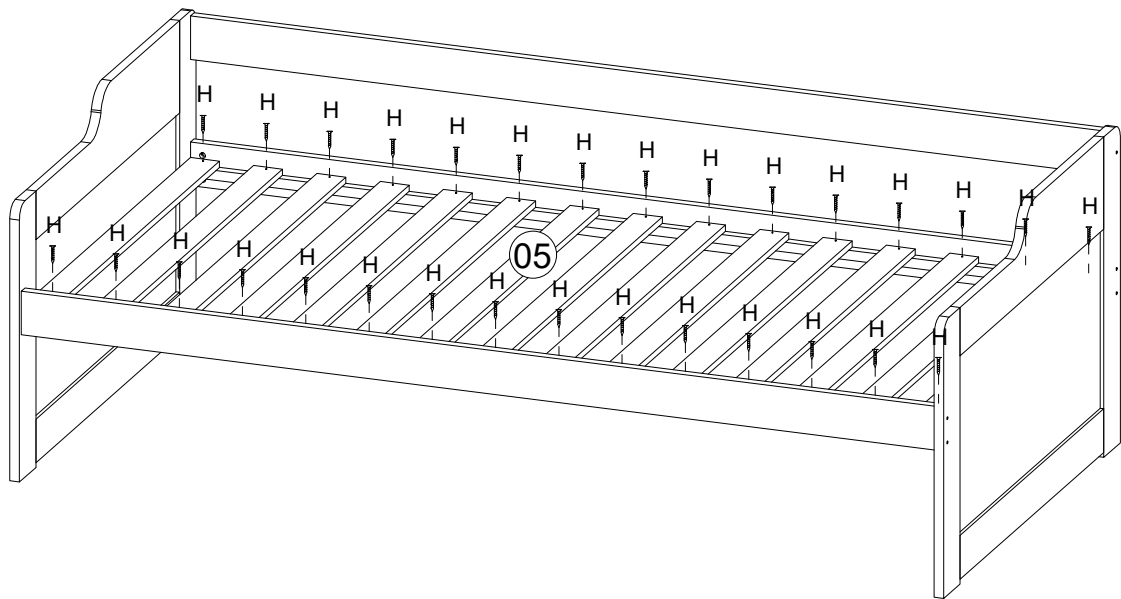

Attach panel [5] to the unit and secure with screw (H).

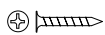
H		30
$\phi 4 \times 30$		

05

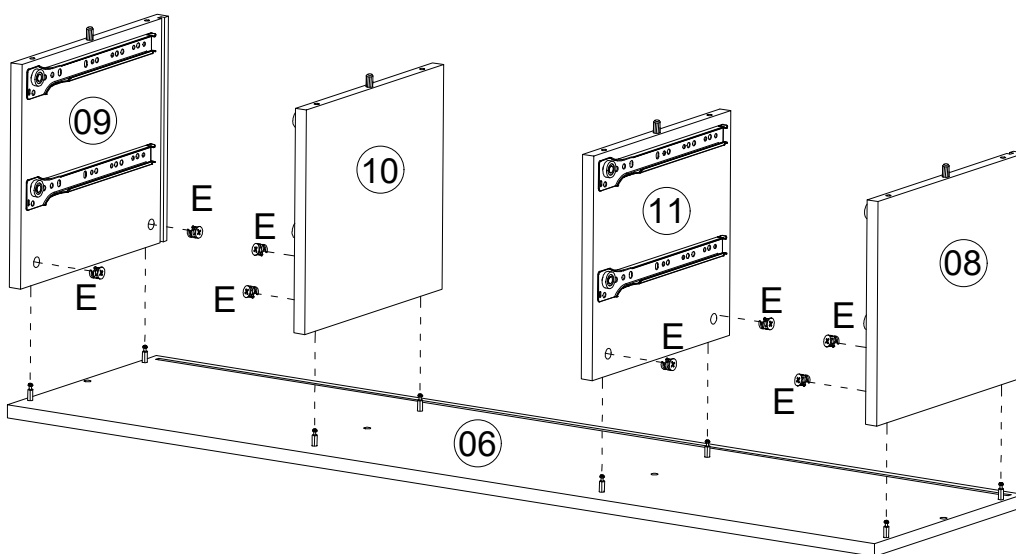

Attach panel [8][9][10][11] to panel [6] and secure with nut(E).

E		08
$\phi 15 \times 11$		

06

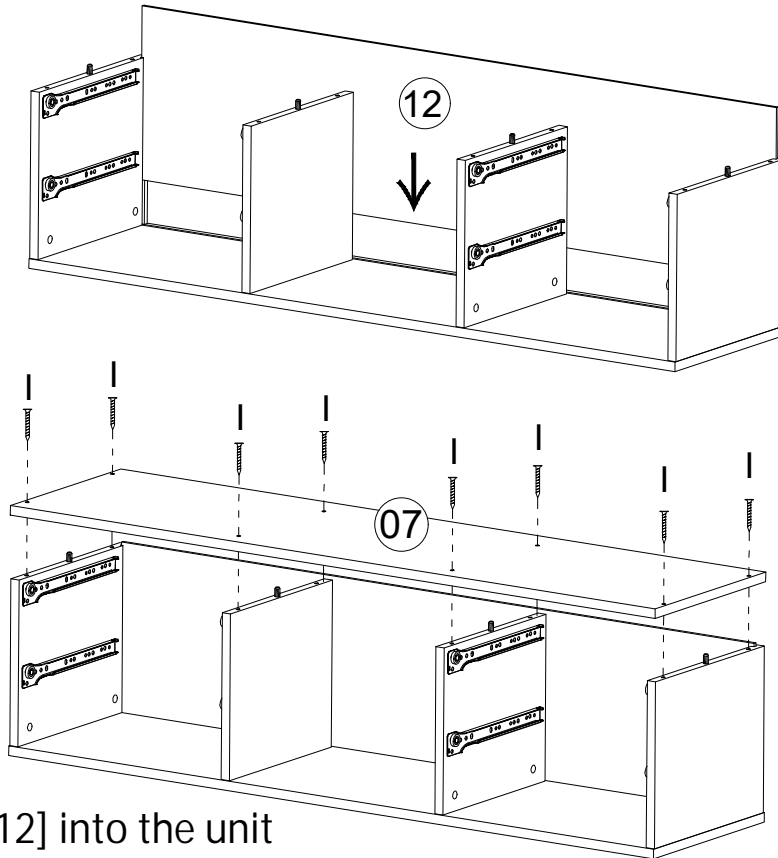

Insert panel [12] into the unit and attach panel [7] to top, secure with screw(I).

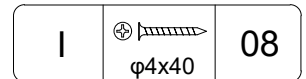

07

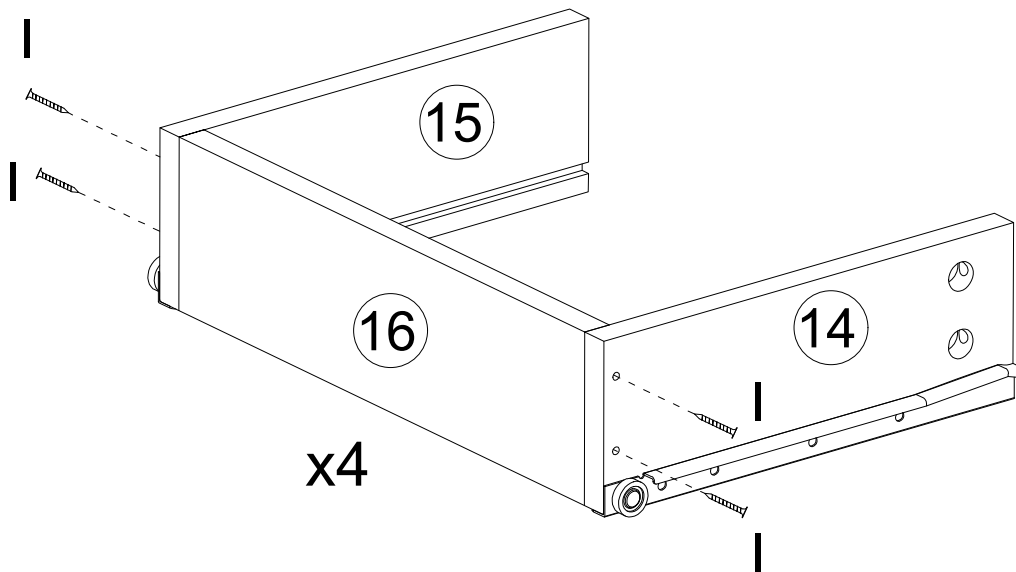

Attach panel[14]][15] to panel [16] and secure with screw(I).

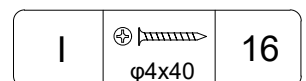

08

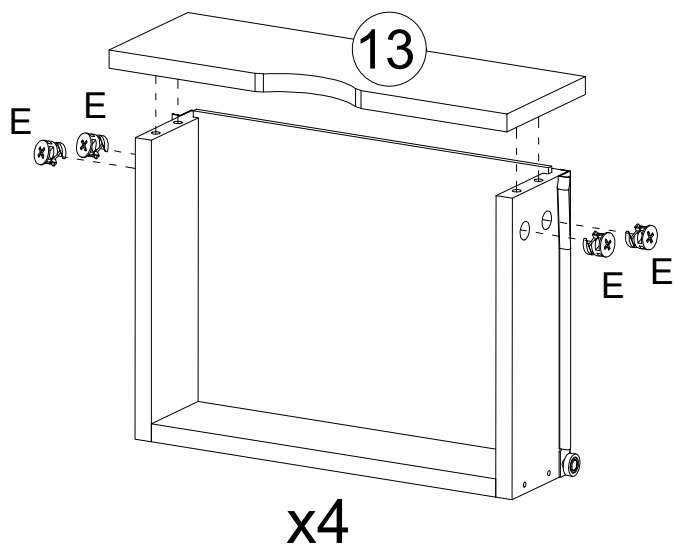
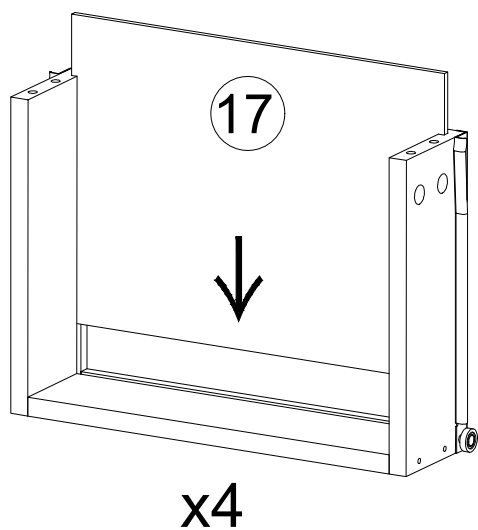

Insert panel [17] into the unit.

Attach panel [13] on the top and secure with locking nut(E).

E		16
$\varnothing 15 \times 11$		

09

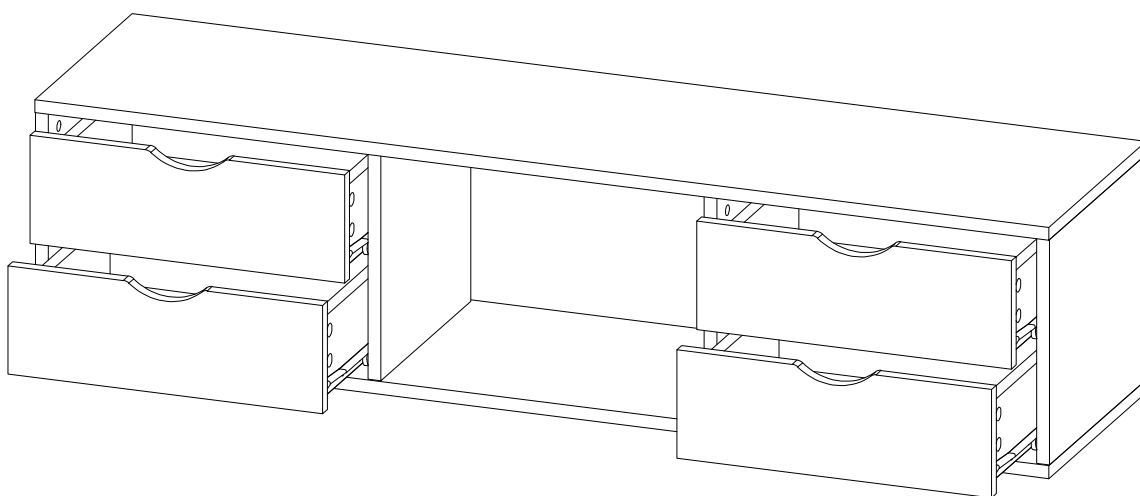

10

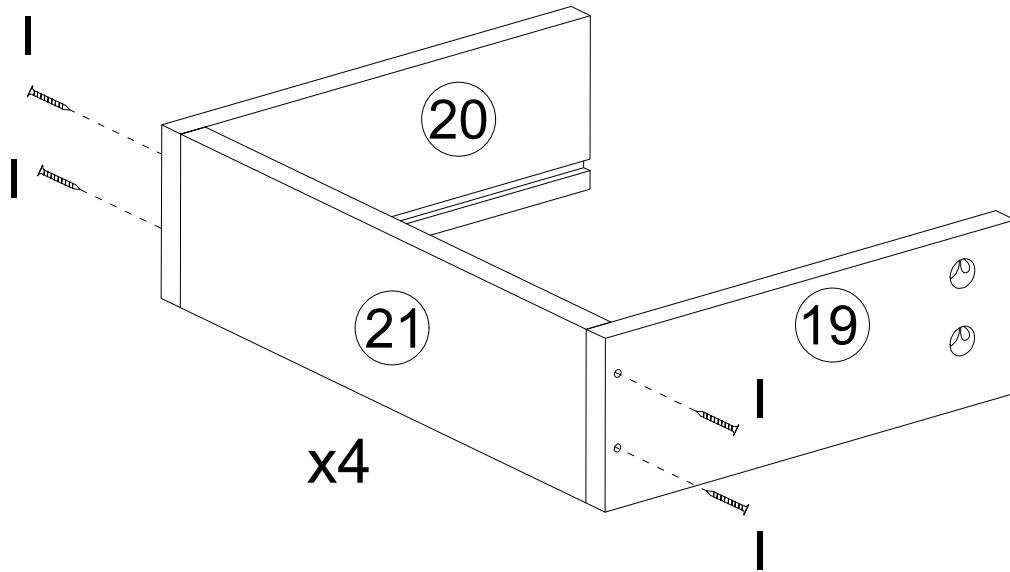

Attach panel[19][20] to panel [21] and secure with screw(I).

I	 φ4x40	16
---	--	----

11

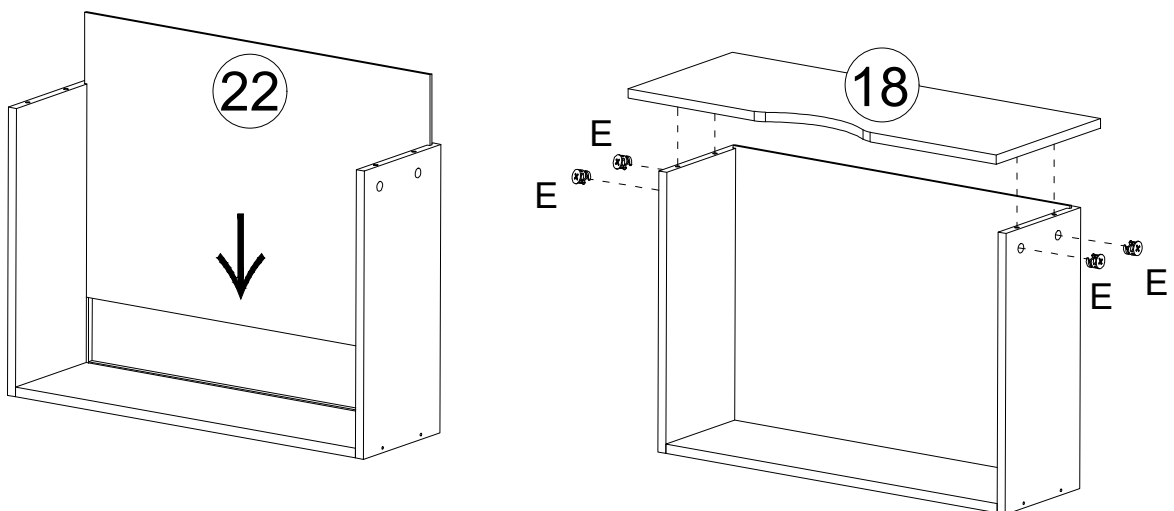



Insert panel [22] to the unit.
Attach panel [18] on the top and secure with locking nut(E).

E	 φ15x11	04
---	---	----

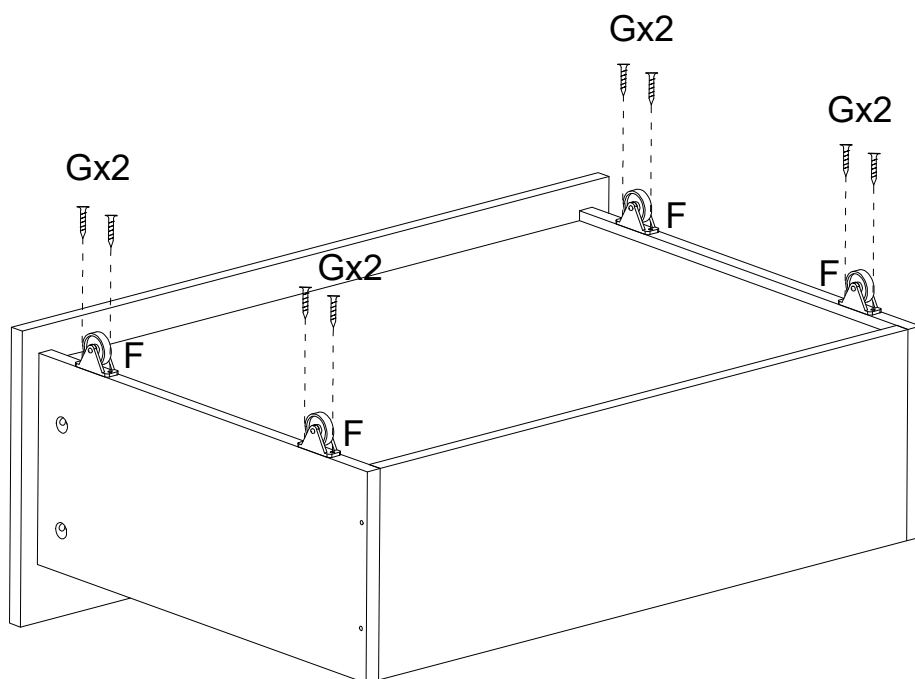
12



Attach wheel (F) and secure with screw(G) as shown.

F		04
G	 φ3x14	08

13

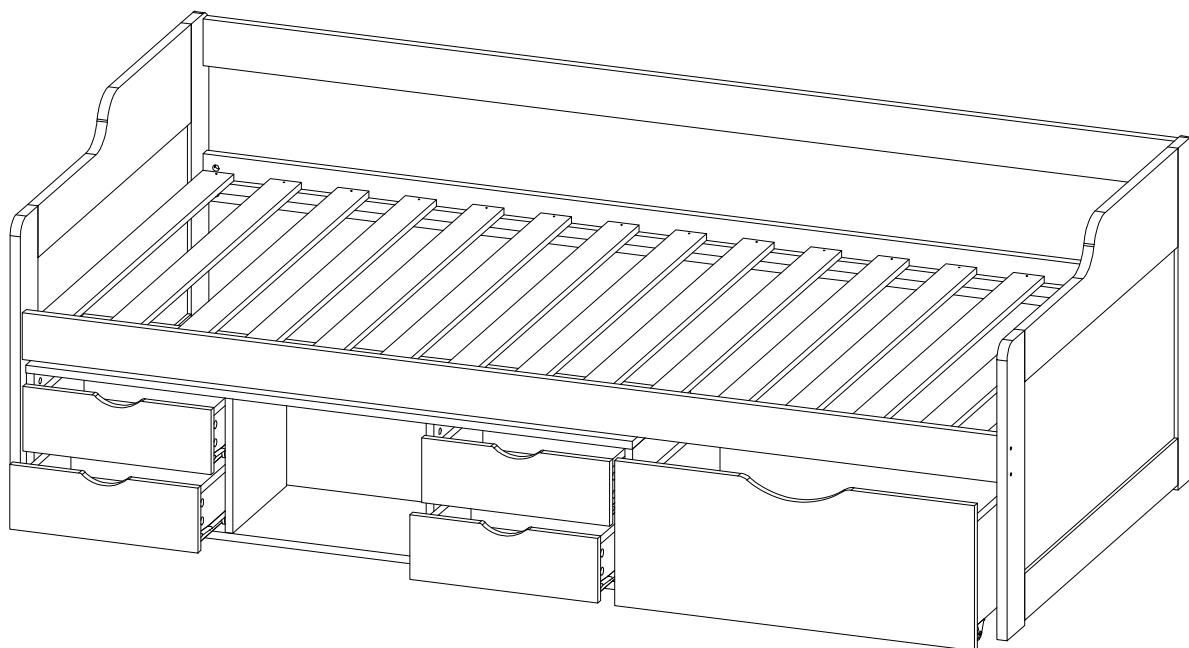

RETURN / DAMAGE CLAIM INSTRUCTIONS

1. **DO NOT** discard of the box / original packaging.

In case a return is required, the item must be returned in original box. Without this your return will not be accepted.

2. Take a photo of the box markings.

A photo of the markings (text) on the box is required in case a part is needed for replacement. This helps our staff identify your product number to ensure you receive the correct parts.

3. Take a photo / Video of Damage (if applicable).

A photo /Video of the damage is always required to file a claim and get your replacement or refund processed quickly. Please make sure you have the box even if it is damaged.

4. Send us an email with the images requested.

Email us directly with the attached images, order number (SOXXXX) and a description of your claim.

Auckland / Waikato / BOP Branch: sales@tsbliving.co.nz
Christchurch Branch: customersupport@tsbliving.co.nz
Wellington Branch: wellington@tsbliving.co.nz