

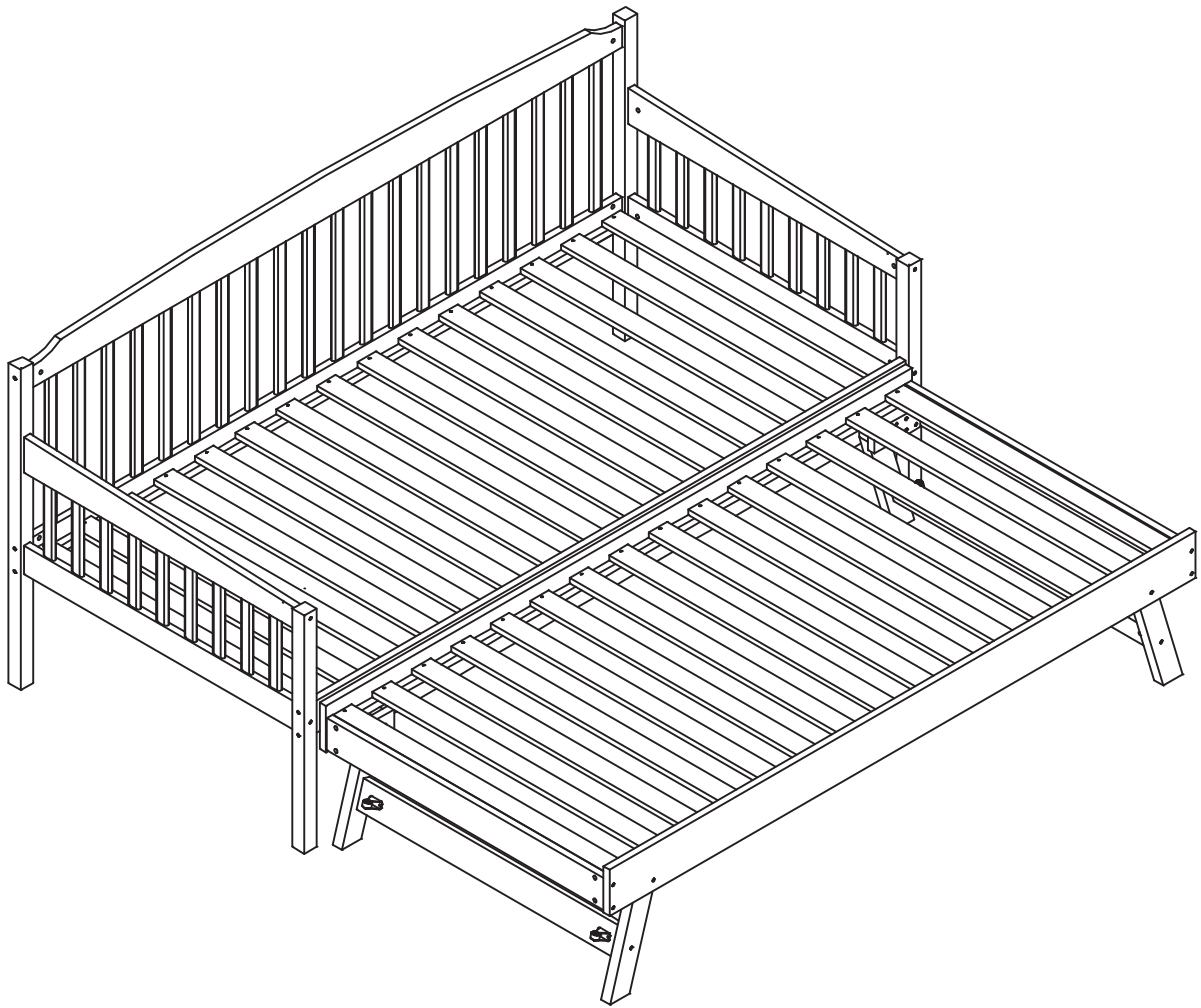

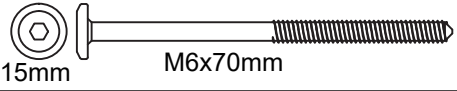

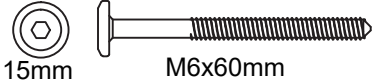

# Assembly Instructions

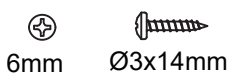

## HARDWARE

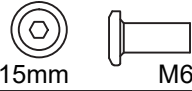
A	 15mm M6x70mm	18
B	 15mm M6x60mm	16
C		30
D	 6mm Ø3x14mm	16
E	 Ø50	04

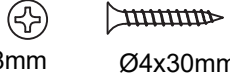
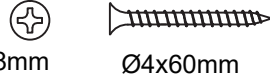
F	 15mm M6x18mm	04
G	 Ø8x30mm	34
H		02
I	 8mm Ø4x30mm	60
J	 8mm Ø4x60mm	16

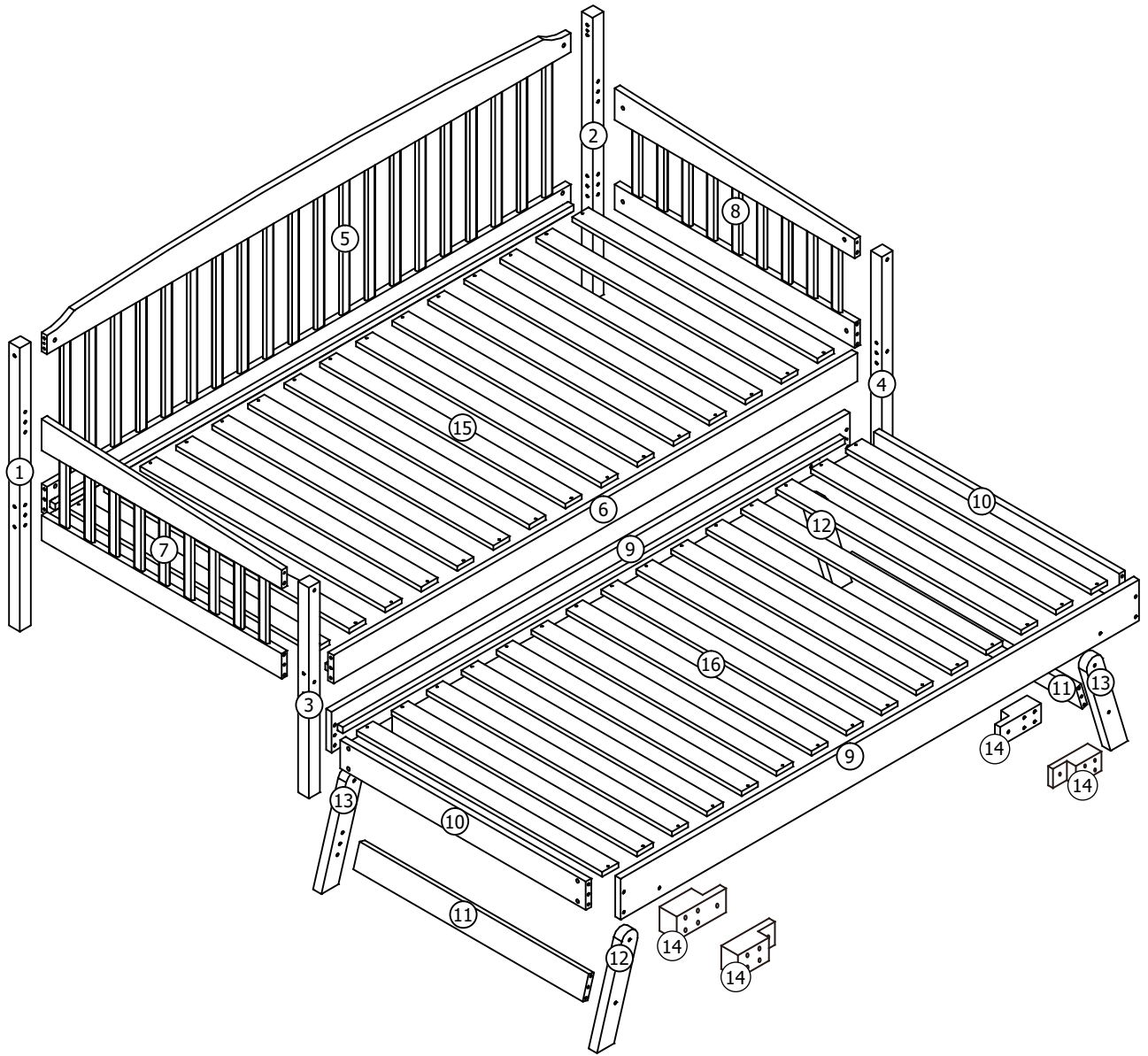

# 01

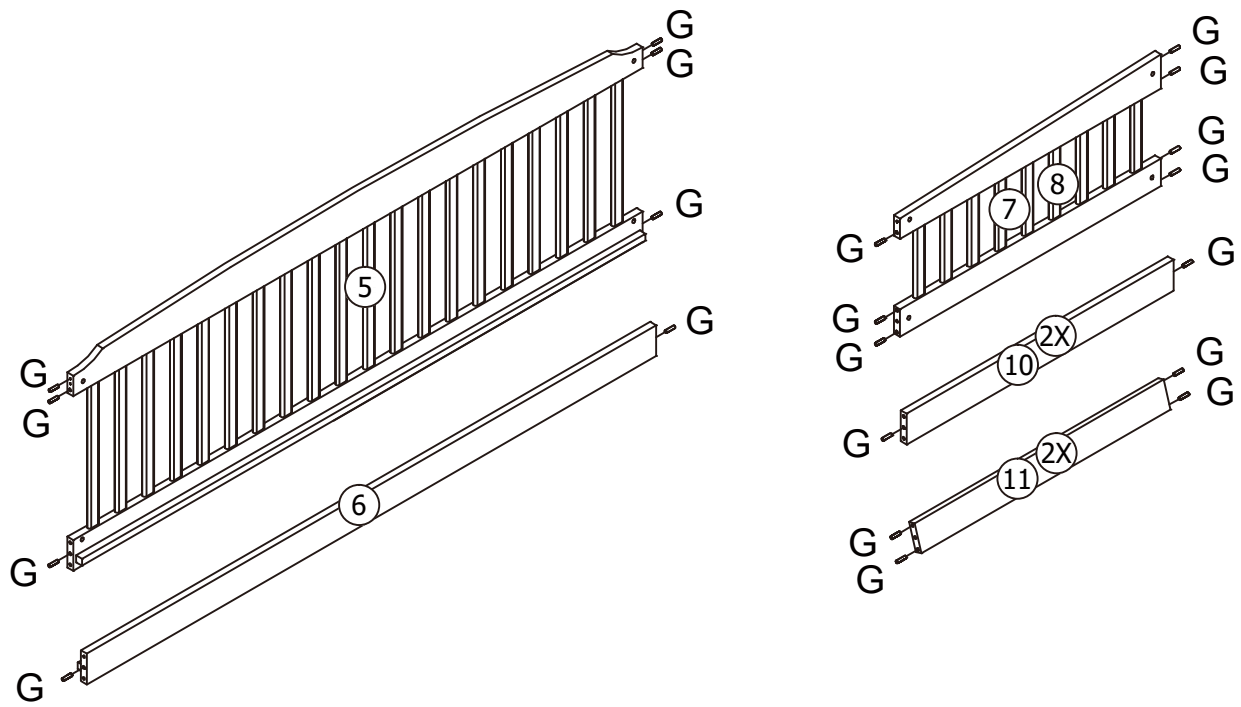



Insert dowel(G) into panel [5][6][7][8][10][11].

G	 Ø8x30mm	34
---	--	----

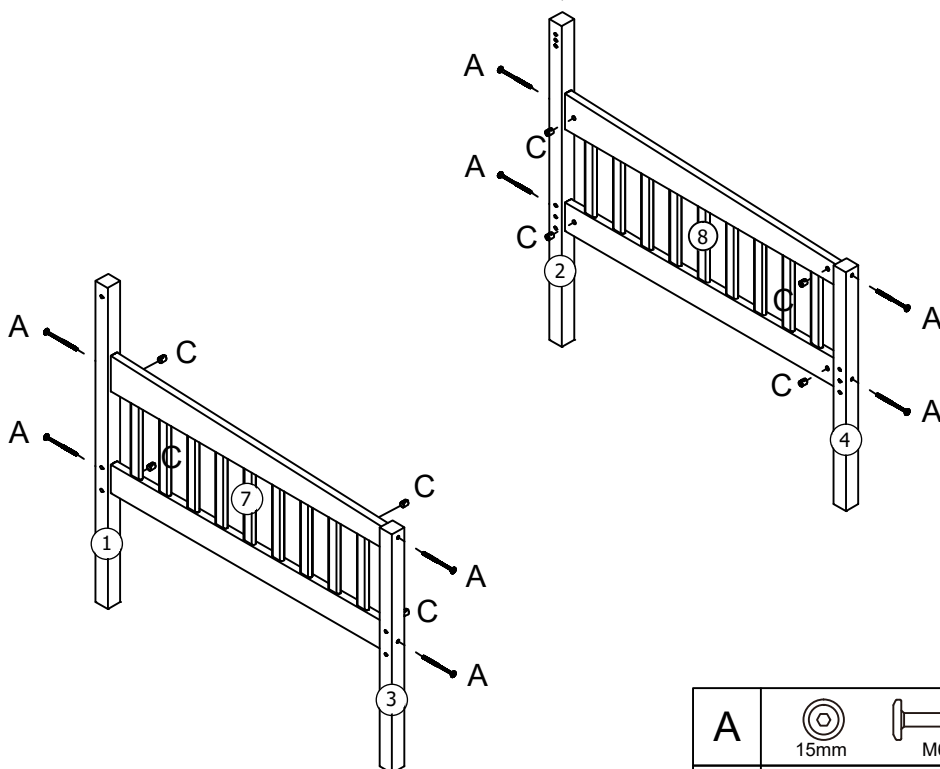
**02** Attach bar [1][3] to panel [7]; bar [2][4] to panel [8], secure with screw(A) and nut (C).



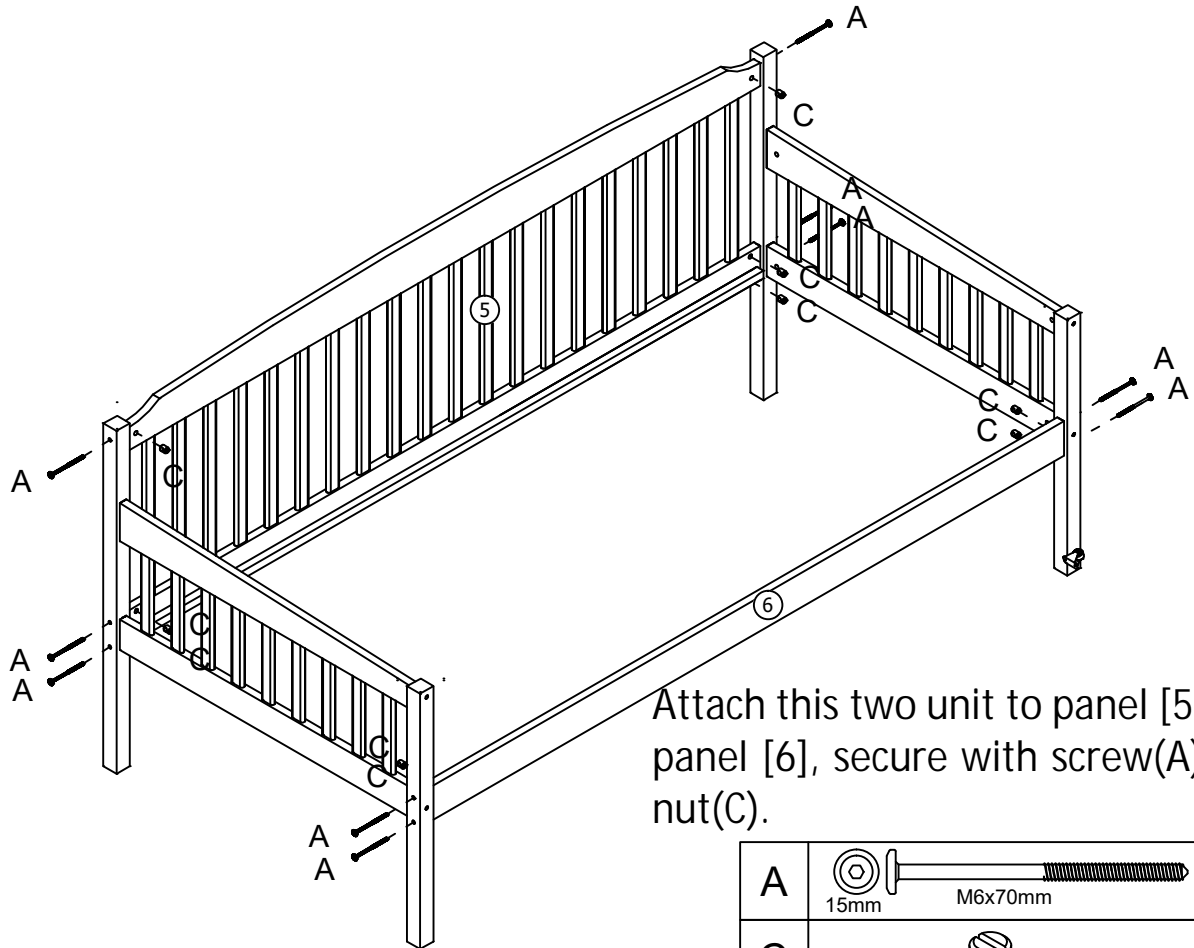

A	 15mm	 M6x70mm	08
C			08

# 03



Attach this two unit to panel [5] and panel [6], secure with screw(A) and nut(C).

A	 15mm M6x70mm	10
C		10

# 04

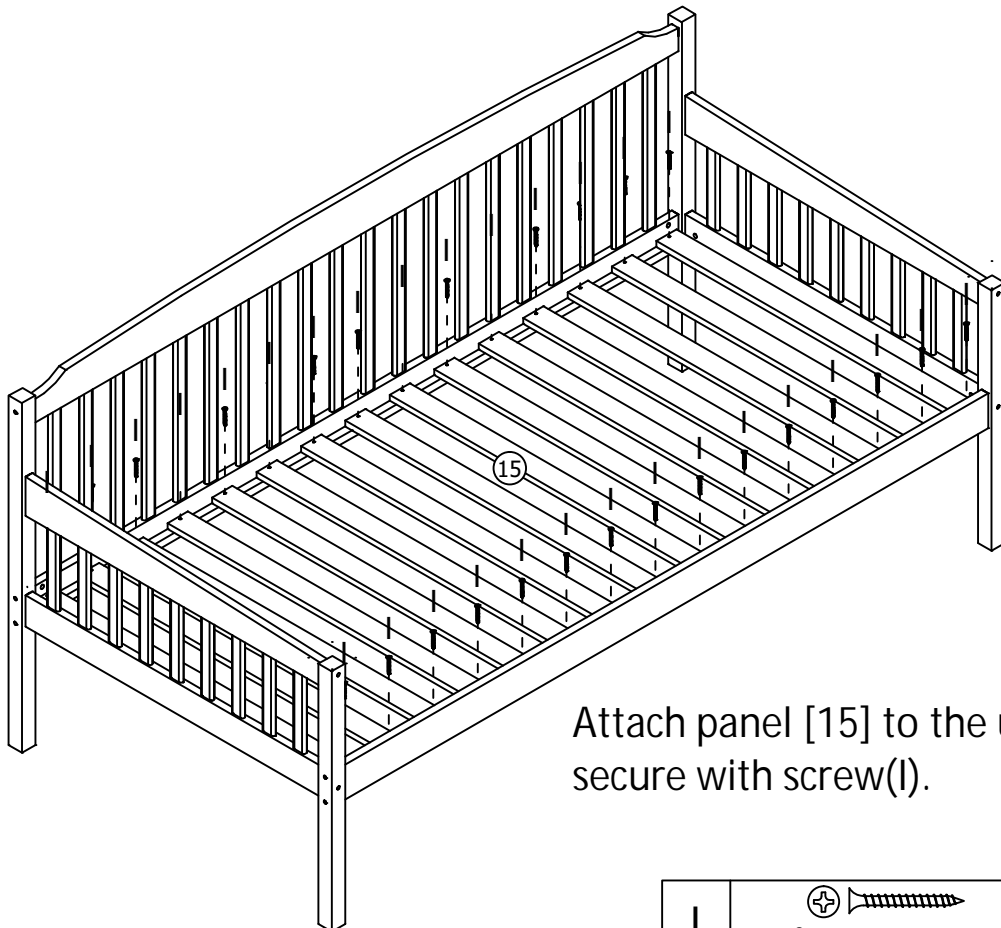

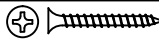

Attach panel [15] to the unit and secure with screw(I).

I	 8mm Ø4x30mm	30
---	---	----

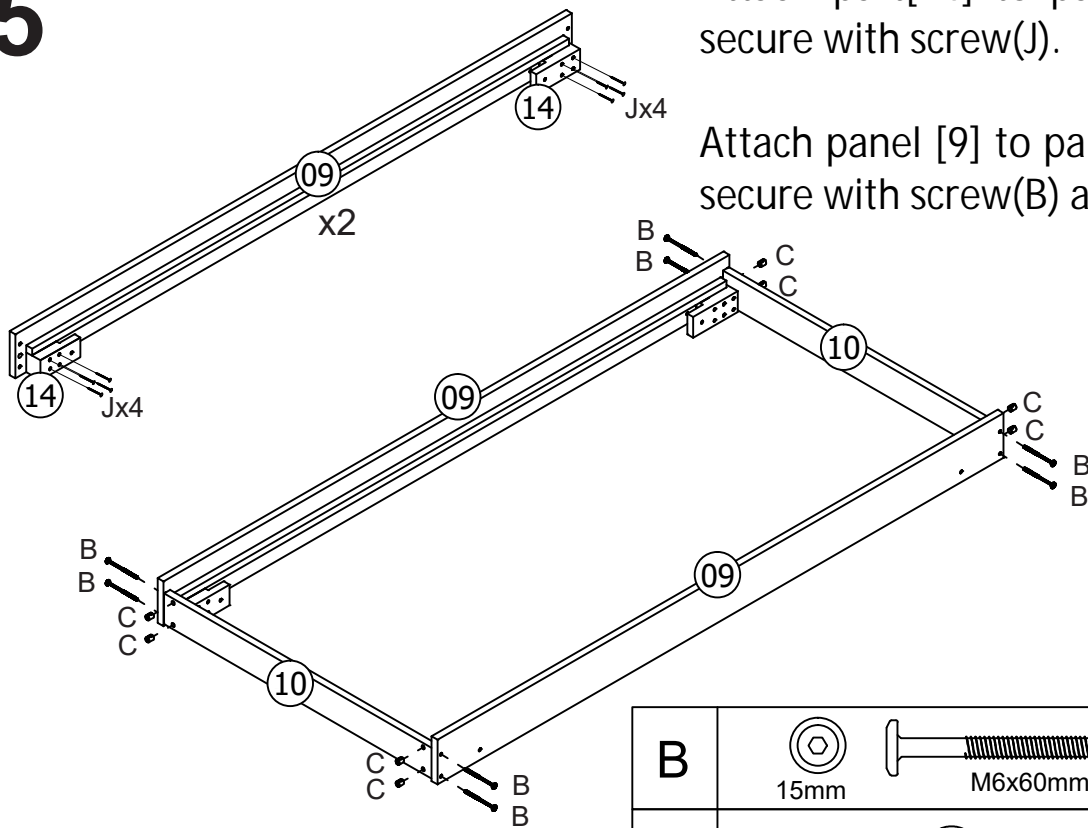

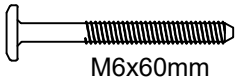

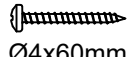

# 05

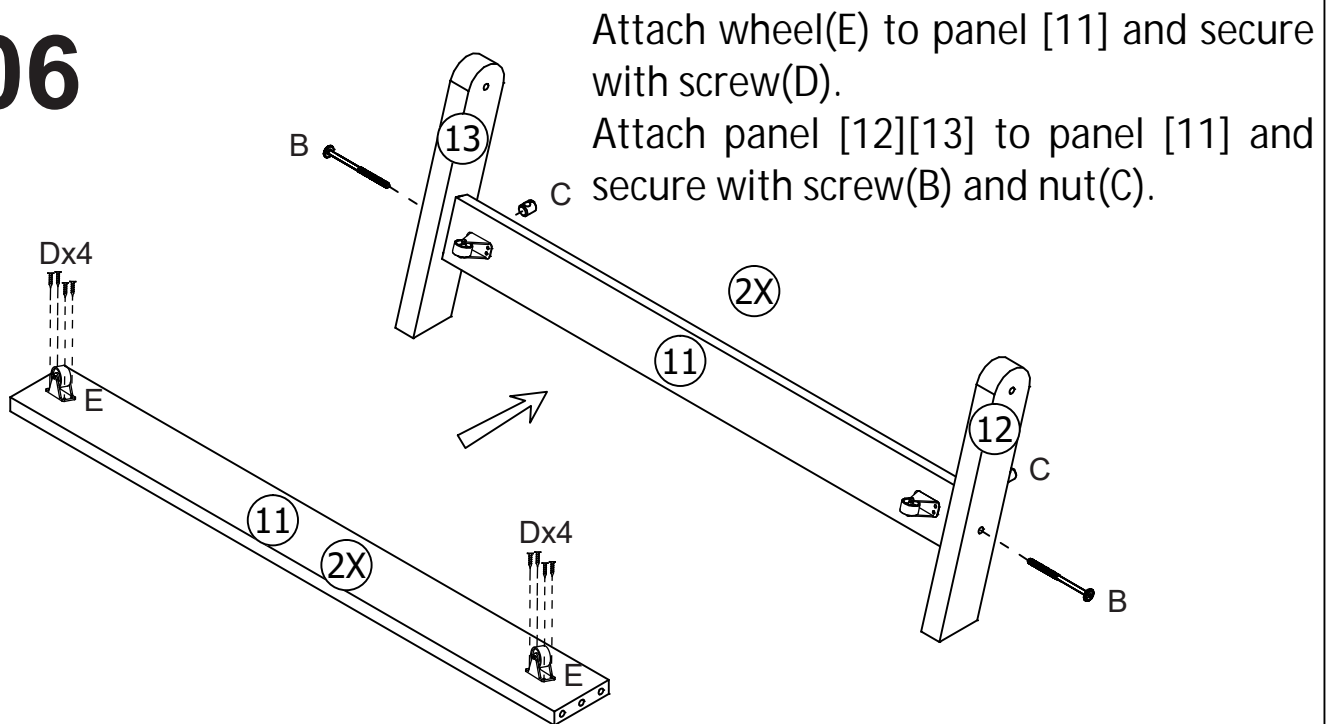

B	 15mm	 M6x60mm	08
C			08
J	 8mm	 Ø4x60mm	16

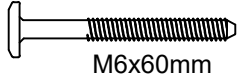
# 06





E	 Ø50	04	B	 15mm	 M6x60mm	04
D	 6mm	 Ø3x14mm	16	C		04

# 07

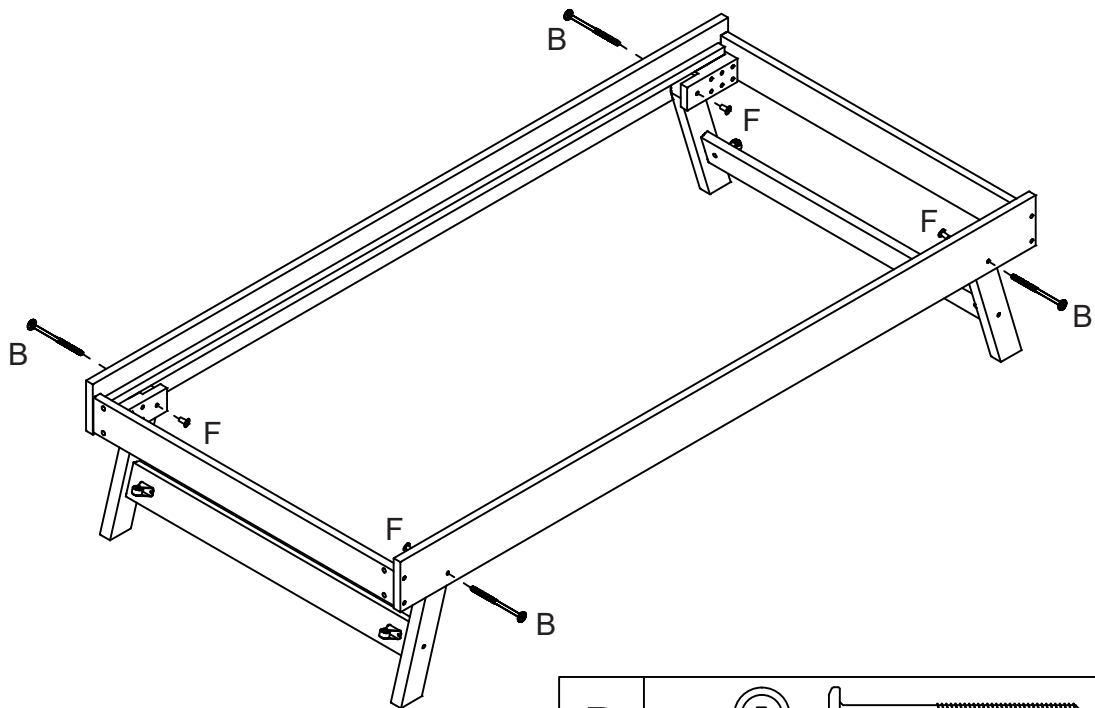
Attach the legs to the unit and secure with screw(B) and (F).

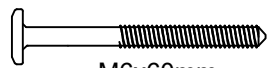

B	 15mm	 M6x60mm	04
F	 15mm	 M6x18mm	04

# 08

Attach panel [16] to the unit and secure with screw(I).

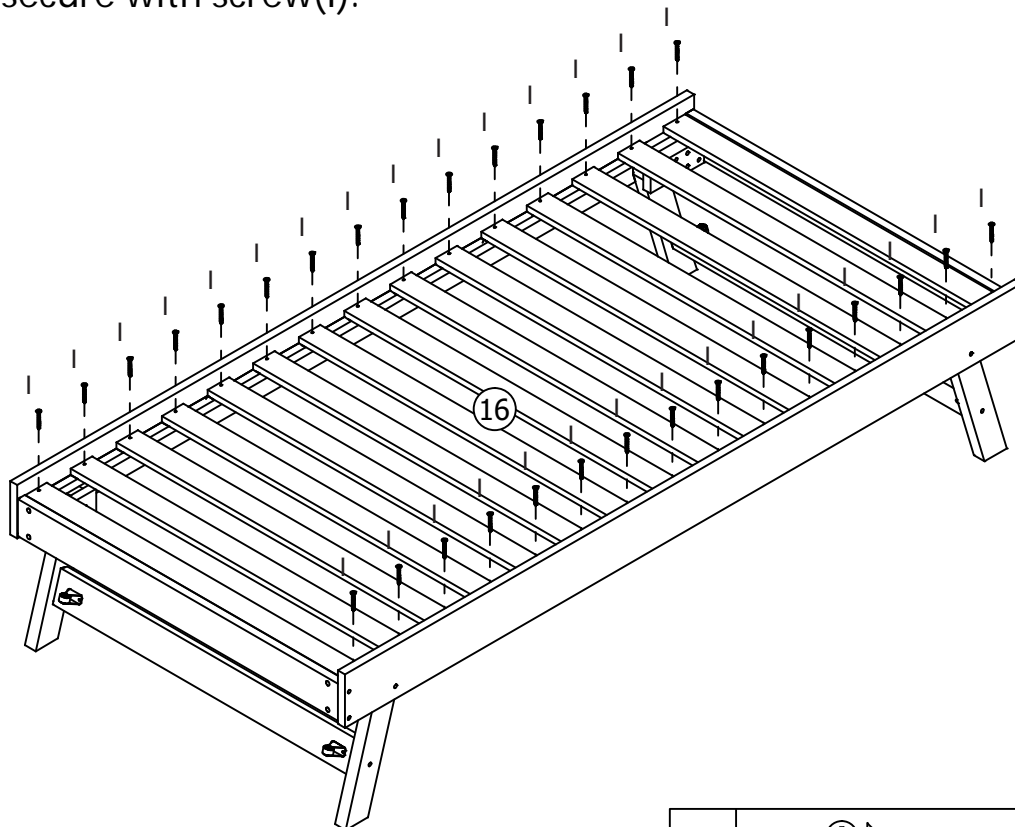

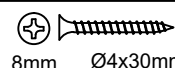
I	 8mm Ø4x30mm	30
---	--	----

09

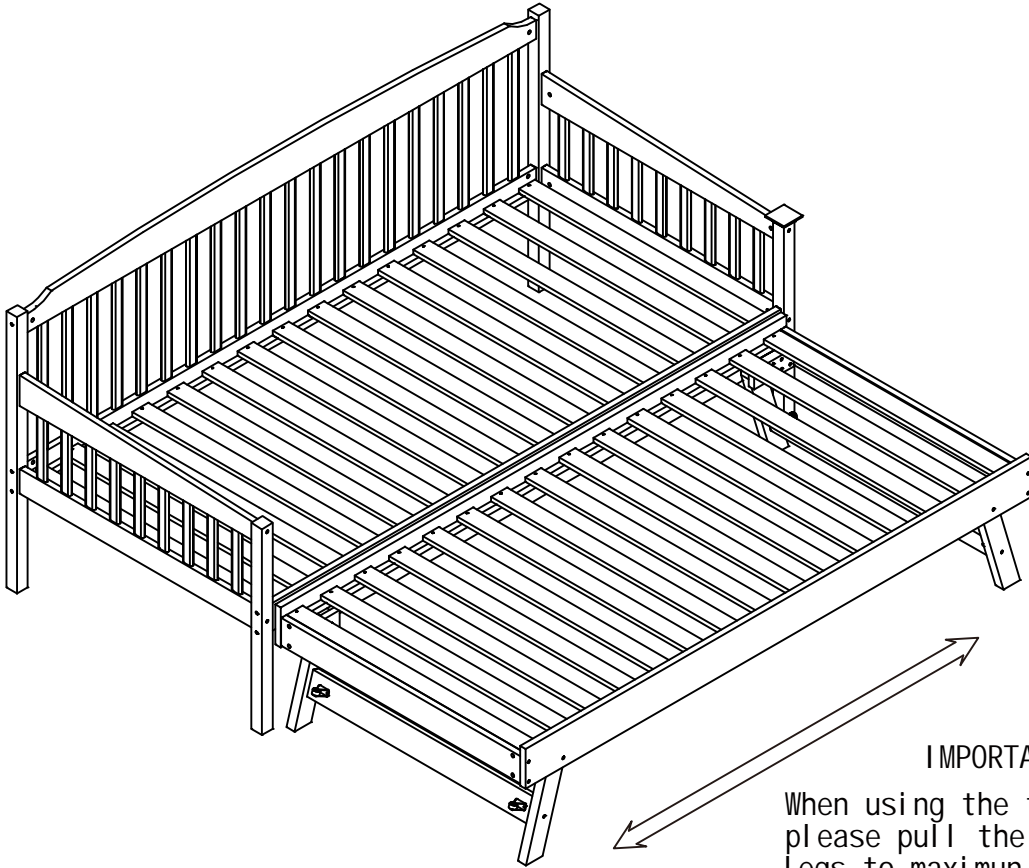

**IMPORTANT!!!**  
When using the trundle bed,  
please pull the four folding  
legs to maximum.

10

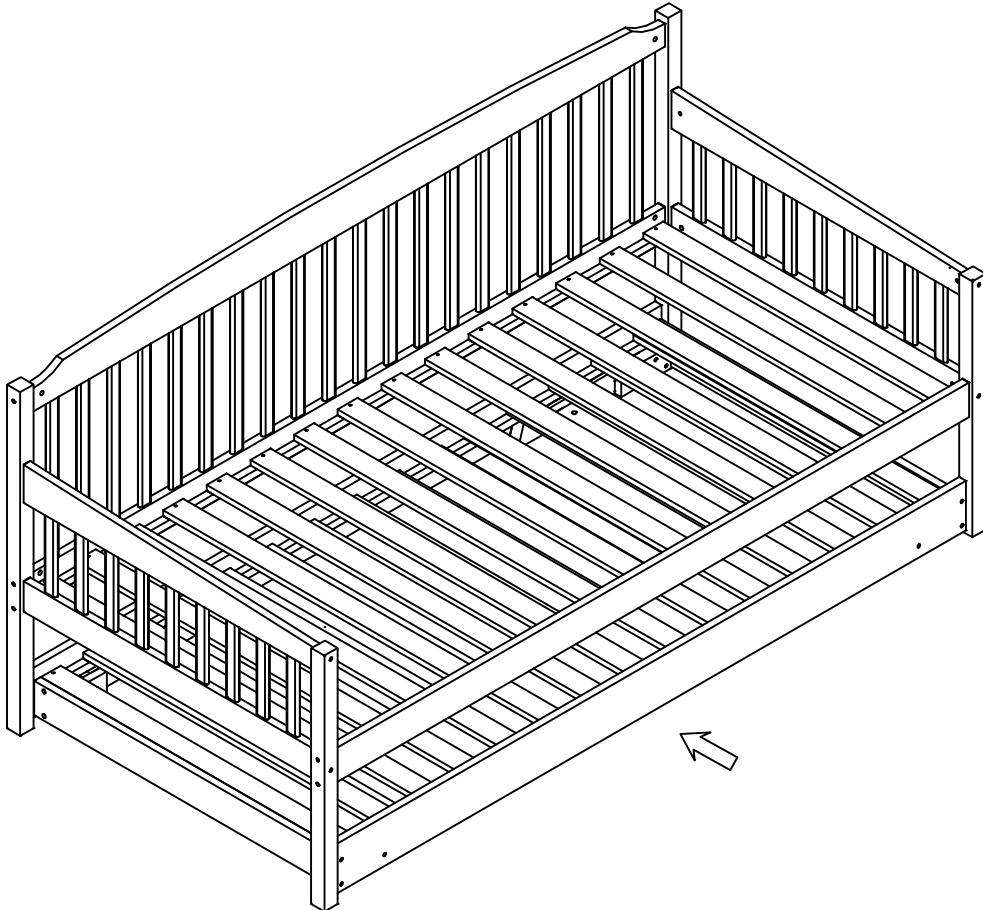

# **RETURN / DAMAGE CLAIM INSTRUCTIONS**

## 1. **DO NOT** discard of the box / original packaging.

In case a return is required, the item must be returned in original box. Without this your return will not be accepted.

## 2. Take a photo of the box markings.

A photo of the markings (text) on the box is required in case a part is needed for replacement. This helps our staff identify your product number to ensure you receive the correct parts.

## 3. Take a photo / Video of Damage (if applicable).

A photo /Video of the damage is always required to file a claim and get your replacement or refund processed quickly. Please make sure you have the box even if it is damaged.

## 4. Send us an email with the images requested.

Email us directly with the attached images, order number (SOXXXX) and a description of your claim.

Auckland / Waikato / BOP Branch: [sales@tsbliving.co.nz](mailto:sales@tsbliving.co.nz)  
Christchurch Branch: [customersupport@tsbliving.co.nz](mailto:customersupport@tsbliving.co.nz)  
Wellington Branch: [wellington@tsbliving.co.nz](mailto:wellington@tsbliving.co.nz)