

12 TON SHOP PRESS

INSTRUCTION MANUAL

RETAIN THIS MANUAL FOR FUTURE REFERENCE

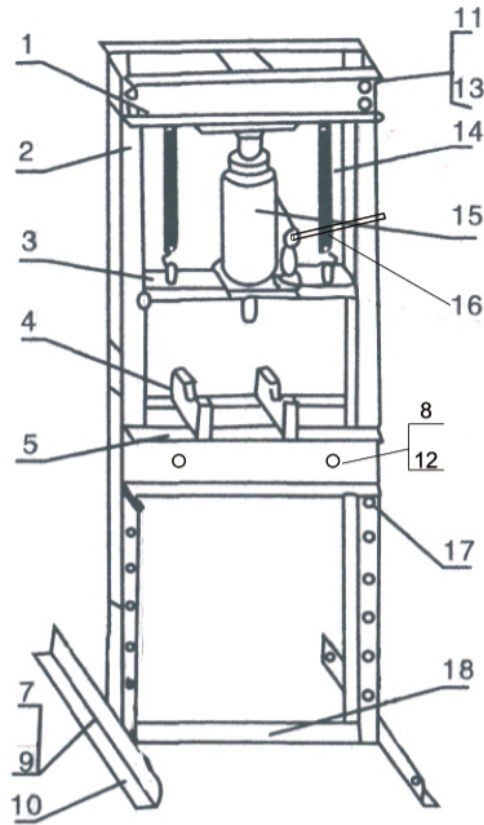

PARTS LIST:

NO	DESCRIPTION	QTY	NO	DESCRIPTION	QTY
1	CROSS BEAM	1	10	LEG	2
2	POLE	2	11	BOLT	8
3	JACK PLATE	1	12	NUT M12	2
4	STEEL PLATE	2	13	NUT M14	8
5	ADJUST BEAM	2	14	SPRING	2
			15	JACK	1
7	BOLT	4	16	JACK ROD	1
8	BOLT M12×100mm	2	17	PIN	2
9	NUT	4	18	FIXPLATE	1



PLEASE READ THIS MANUAL CAREFULLY BEFORE USE

PARAMETER

CAPACITY..... 12TON

WORKING RANGE.....0-650MM

WIDTH.....420MM

FEATURE

1. Used for parts straightening,bending and pressing.
2. Multi-position bed for work height adjustment.

OPERATION

1. Place work piece on bed frame.
2. Locate and close release valve by turning it clockwise until tight.
3. Pump handle until the ram nears work piece.
4. Align ram and work piece to ensure center loading.
5. Apply load to work piece by pumping handle.Do not overload work piece.
6. Remove load from work piece by turning release valve counterclockwise.Stabilize work piece so it does not fall while pressure is released.
7. Remove work piece after ram is fully retracted.

WARNING

- 1.Read and understand the entire instruction manual before attempting setup,or operation of this machine.
- 2.This press is designed and intended for use by properly trained and experienced personnel only. If you are not familiar with the proper and safe operation of a hydraulic press, do not use until proper training and knowledge has been obtained.
- 3.Do not operate this press beyond its rated capacity.
- 4.This press is designed for pressing, bending, and straightening purposes only. DO NOT compress springs or other objects that could be ejected from the press. DO NOT compress objects that could shatter.
- 5.Check the press for loose or damaged parts before each operation. Replace damaged

parts and tighten all loose bolts before operating.

- 6.Some parts being pressed may have a tendency to pop out of the press or explode under pressure.Protect yourself accordingly. Keep hands away from the pressure head and out of support rod holes. Always center the work piece on the table plates and center the pressure head on the work piece to prevent injury by ejection of the work piece.
7. Always wear safety glasses/face shields and personal safety equipment.

MAINTENANCE

- 1.Before each use inspect press for damage. Do not use if bent,broken, cracked, leaking or otherwise damaged in any way.
- 2.Periodically, lightly oil all moving parts including the pump piston and hydraulic ram.
- 3.Check hydraulic connections and hoses before each use.Do not use if cut,damaged, leaking or otherwise damaged connections and/or hoses are noted.

Troubleshooting

Symptom	Possible cause	Corrective Action
Plunger can not be moving	The mechanical parts are corrupt	Add lubricate oil or grease
Plunger can not be auto retracted or retract slowly	1. Reservoir overfilled 2. Linkages binding	1. Drain jack oil to proper level 2.Clean and lubricate moving parts
Will not lift to full extension	Jack oil level low	Add jack oil